

REV.	D/ECN NO.	LOCATION	DESIGN CHANGE DESCRIPTION	DATE	SIGN
V10	-	-	Initial issue	2024/04/01	Noah.Xu

N0.	SYMBOL
1	GND
2	D3N
3	D3P
4	GND
5	D2N
6	D2P
7	GND
8	NC
9	NC
10	GND
11	D1N
12	D1P
13	GND
14	D0N
15	D0P
16	GND
17	CLKN
18	CLKP
19	PDN1
20	MCLK
21	RST
22	SCL
23	SDA
24	AF
25	1.8V
26	GND
27	GND
28	VDD
29	VCC_3V3_S0
30	VCC_3V3_S0

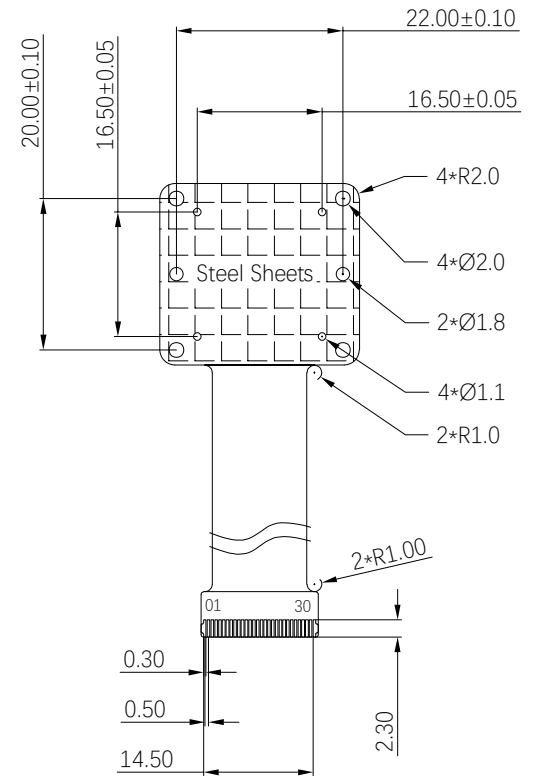

Lens Size	1/2.8INCH	Chip Type	IMX415	GENERAL TOLERANCE			SIGN	DATE	MATERIAL	PART NAME		ACC-1080A		
EFL	2.02mm	Array Size	3864*2192	X. $\pm 0.5$	X. $^\circ \pm 2.0$	DESIGN	Noah.Xu	2024/04/01		FINISH		N/A		
F.NO	2.4	DVDD	1.1V	.X $\pm 0.25$	.X $^\circ \pm 1.5$	APPROVAL			REV.	V10	SCALE	1:1	PROCESS	N/A
View Angle	D: 118.8 $^\circ$ H: 109.9 $^\circ$ V: 74.6 $^\circ$	DOVDD	1.8V	.XX $\pm 0.10$	.XX $^\circ \pm 0.5$	THIRD ANGLE			PAGE 1 OF 1	UNIT	mm	NAMTSO TECHNOLOGY CO., LTD.		
Disforfion	<-3.6%	AVDD	2.9V											

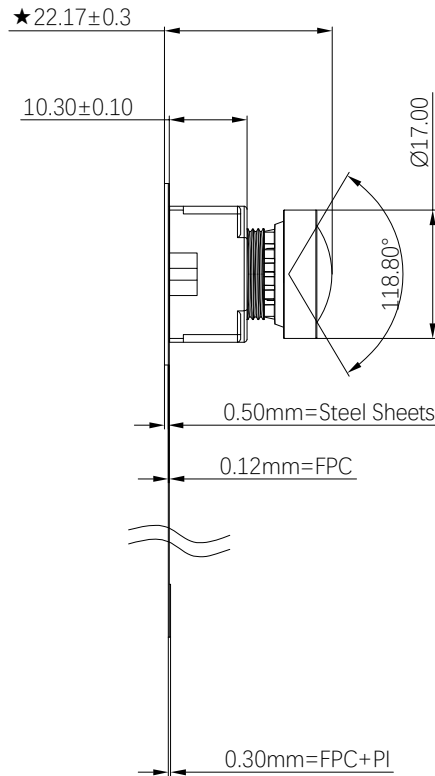
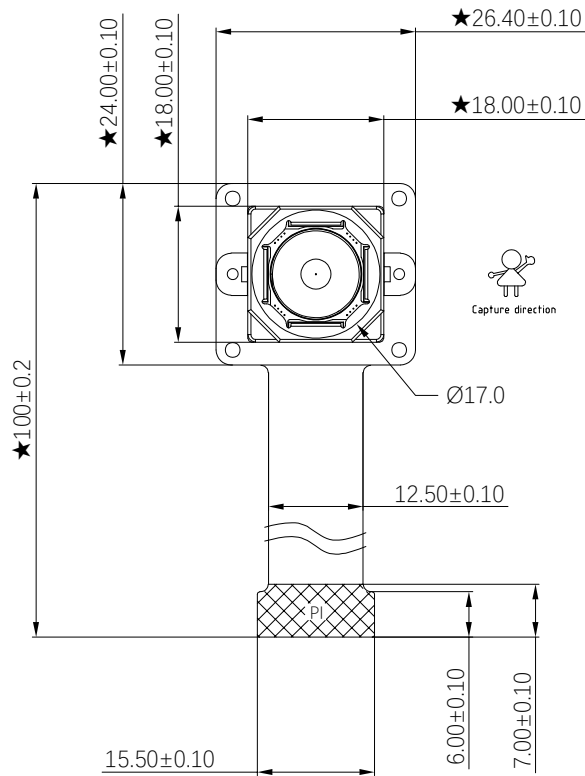