

NAMTSO

Namso Technology Co., Ltd.			
Project:	A10-N305		
File:	LOGO		
Date:	Friday, February 02, 2024	Rev:	V12
Designed_by:	Victor Chen	Sheet:	1

DISPLAY/USB3

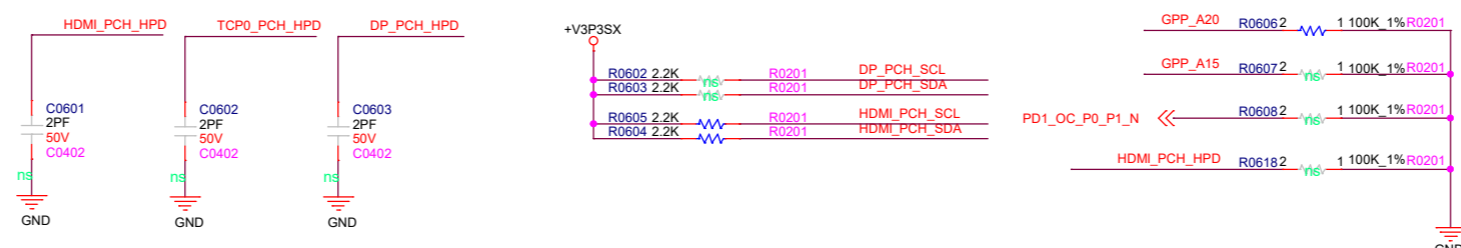
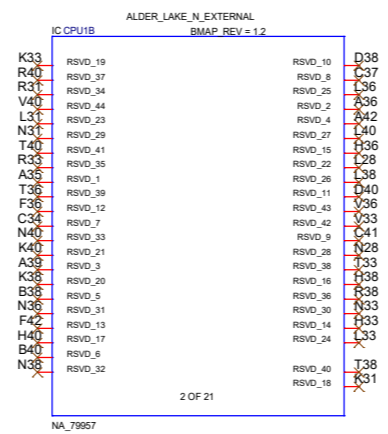
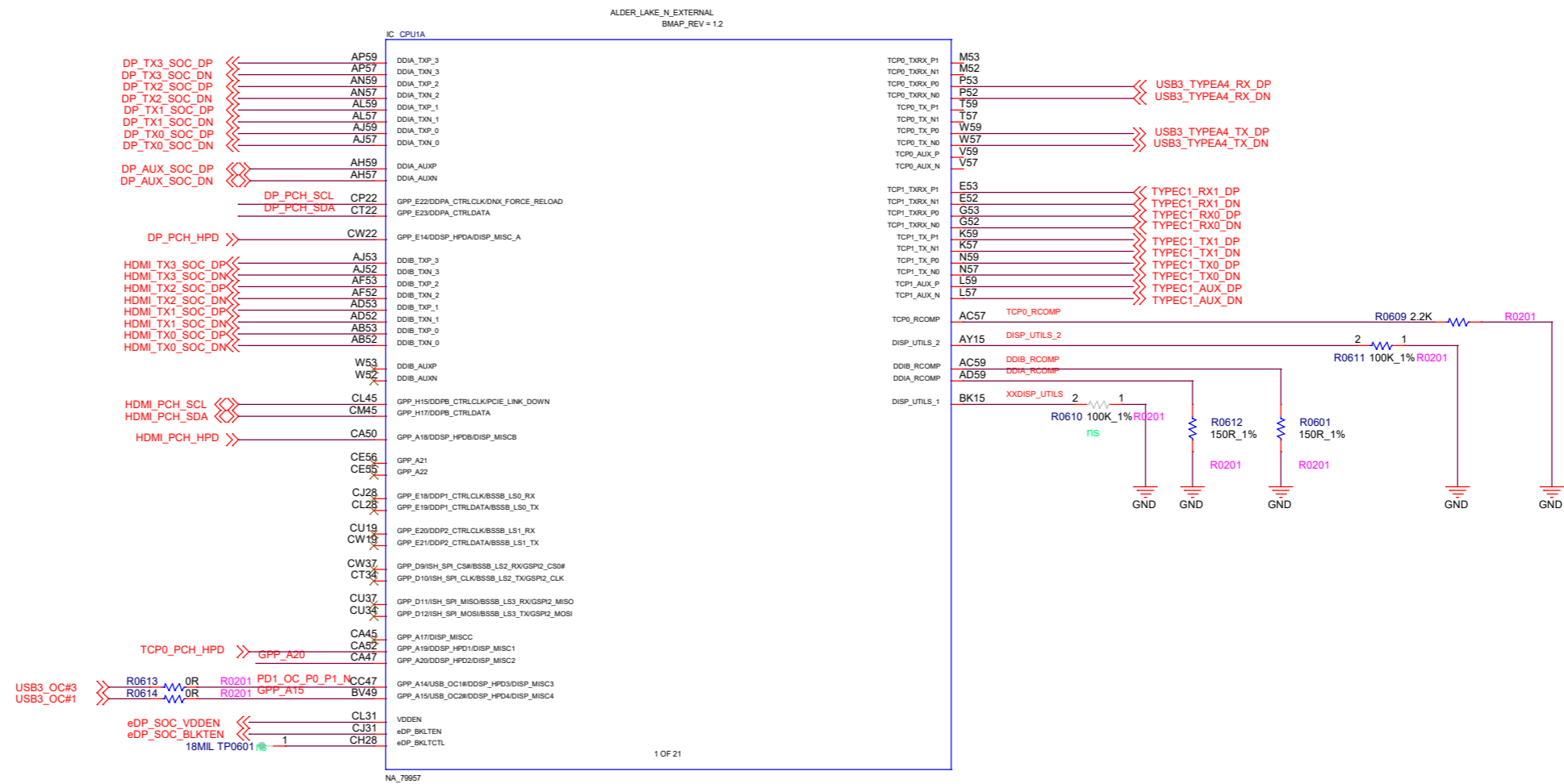

Namts Technology Co., Ltd.			
Project:	A10-N305		
File:	ADL-N(Display/USB3)		
Date:	Friday, February 02, 2024	Rev:	V12
Designed_by:	Victor Chen	Sheet:	2

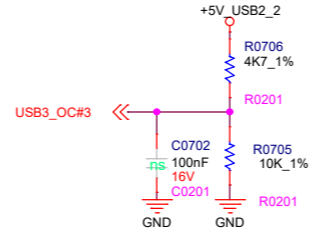
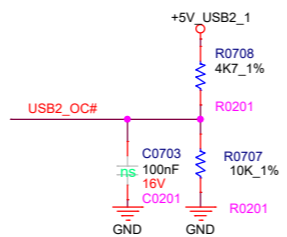
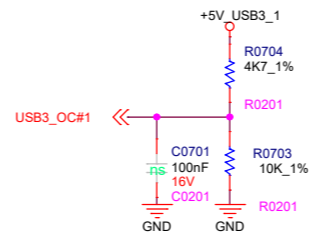
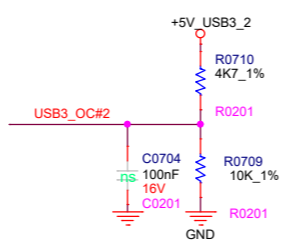
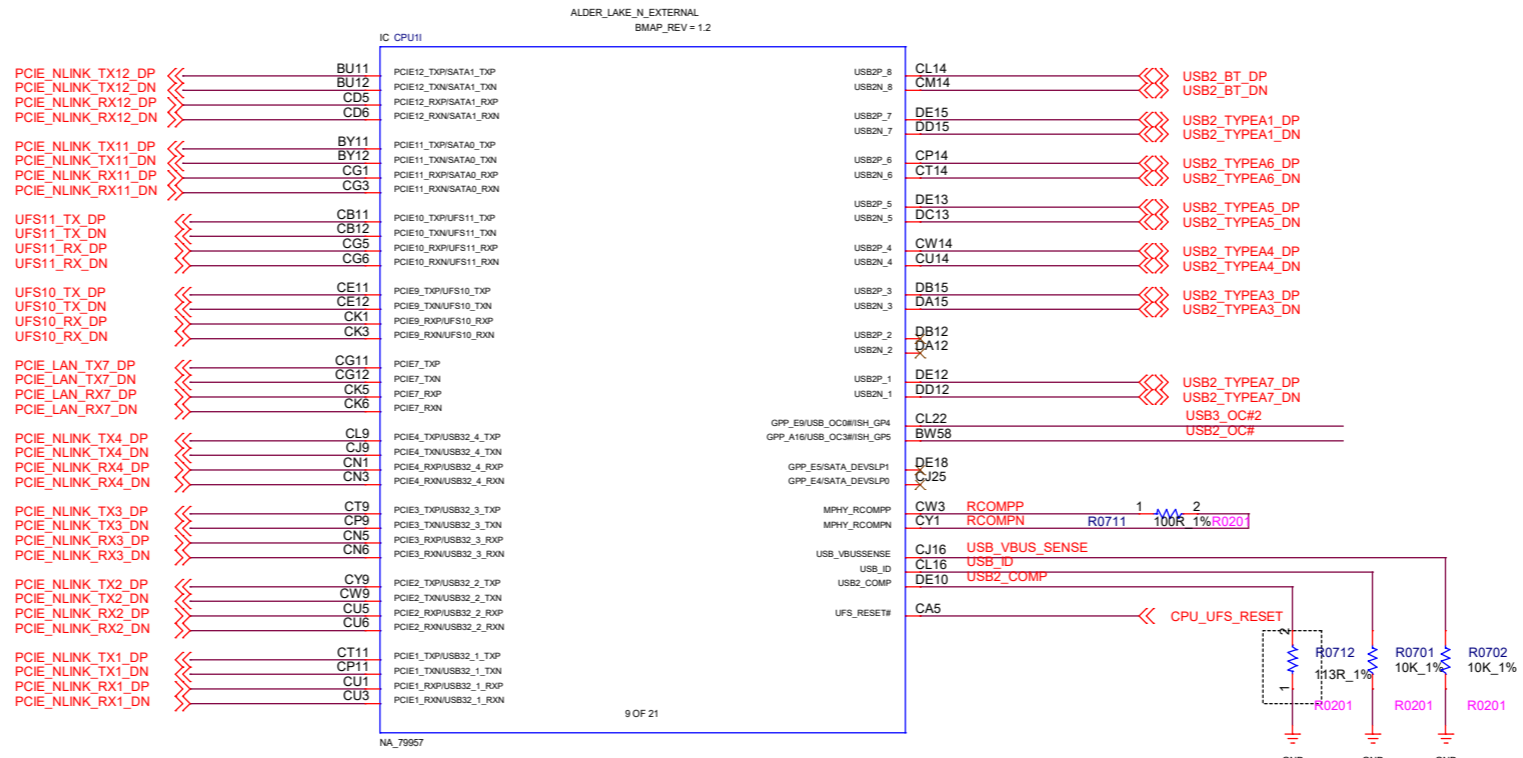

Namtso Technology Co., Ltd.			
Project:	A10-N305		
File:	ADL-N(HSIO)		
Date:	Friday, February 02, 2024	Rev:	V12
Designed_by:	Victor.Chen	Sheet:	3

LPDDR5_A

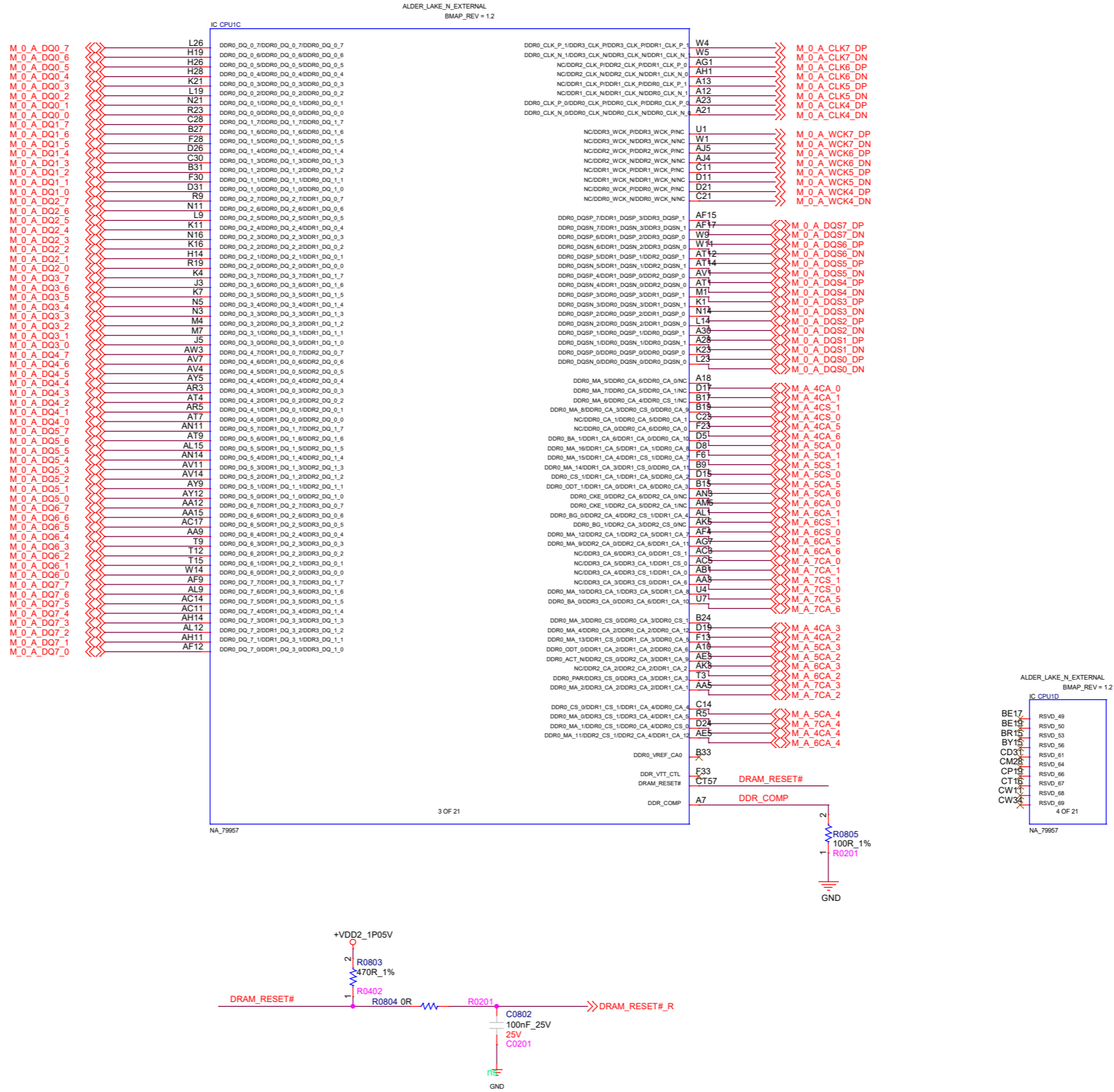

Namtsu Technology Co., Ltd.			
Project:	A10-N305		
File:	ADL-N(LPDDR5_A)		
Date:	Friday, February 02, 2024	Rev:	V12
Designed_by:	Victor Chen	Sheet:	4

SPI/ESPI/HDA/UART

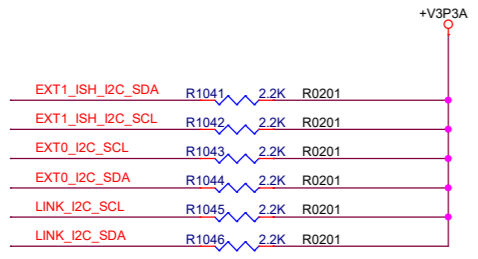
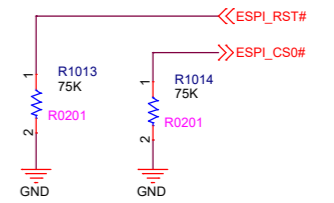
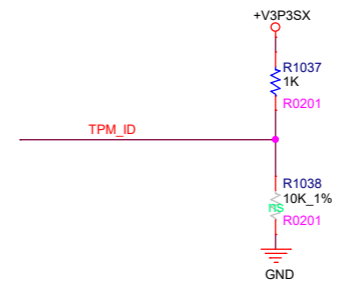
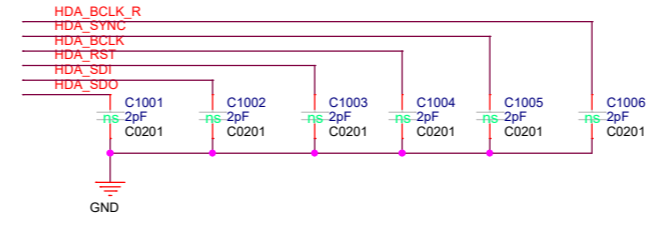
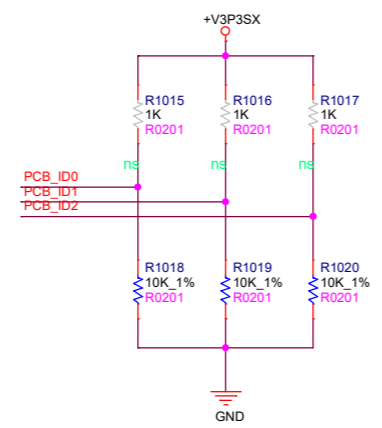
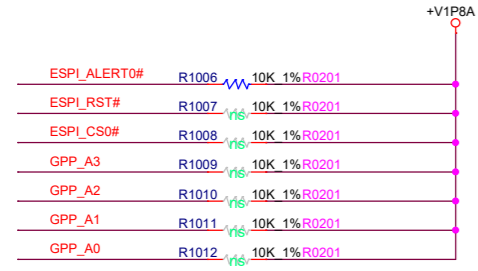
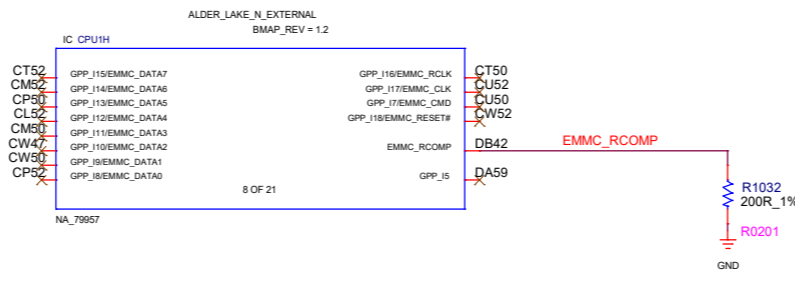
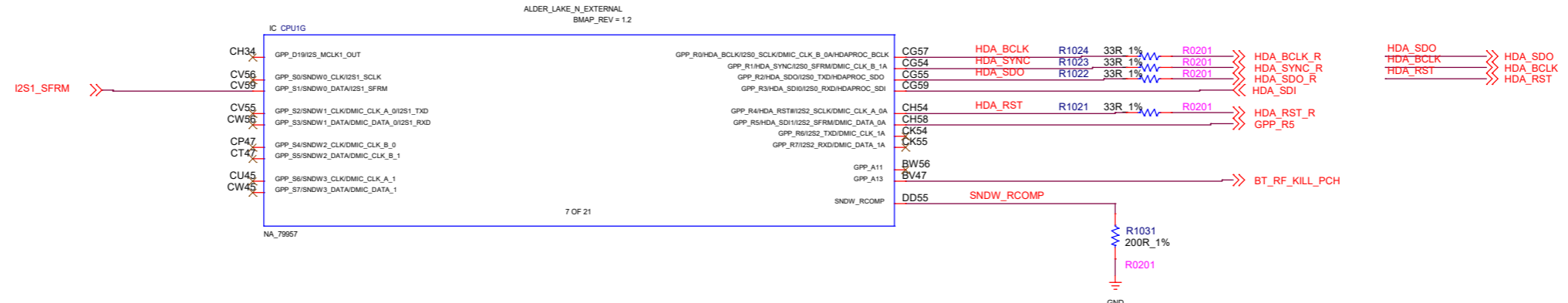

Namtso Technology Co., Ltd.			
Project:	A10-N305		
File:	ADL-N(SPI/ESPI/HDA/UART)		
Date:	Friday, February 02, 2024	Rev:	V12
Designed_by:	Victor Chen	Sheet:	5

SPI/ESPI/HDA/UART

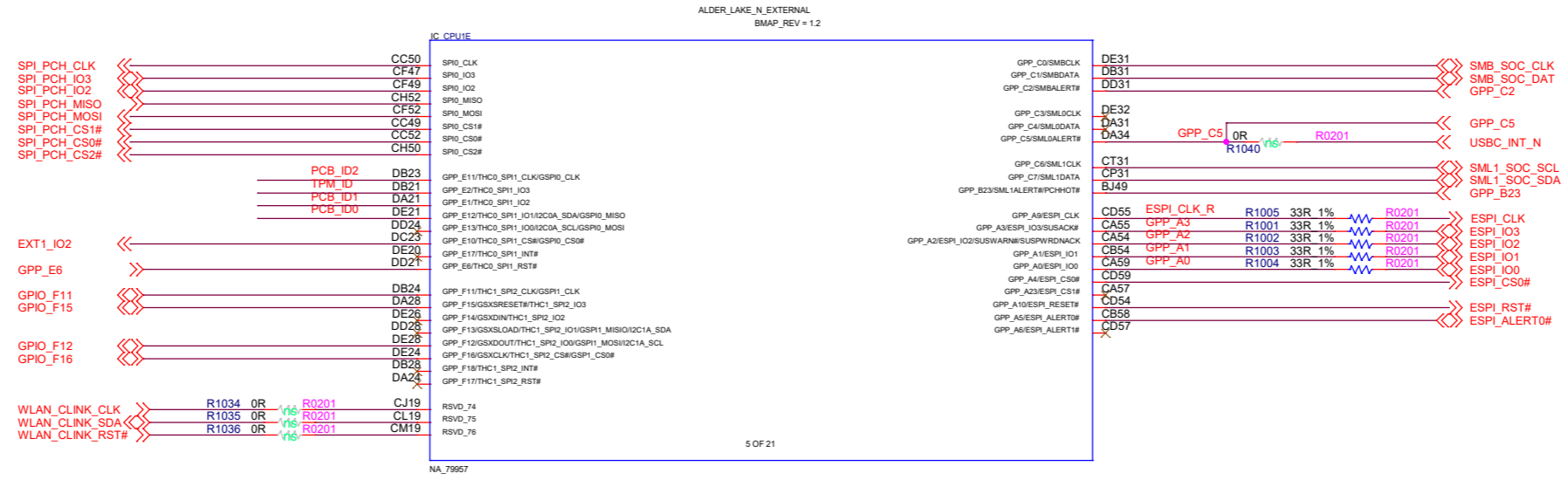

Namtso Technology Co., Ltd.			
Project:	A10-N305		
File:	ADL-N(SPI/ESPI/HDA/UART)		
Date:	Friday, February 02, 2024	Rev:	V12
Designed_by:	Victor Chen	Sheet:	6

ADL-N(CLK/RTC)

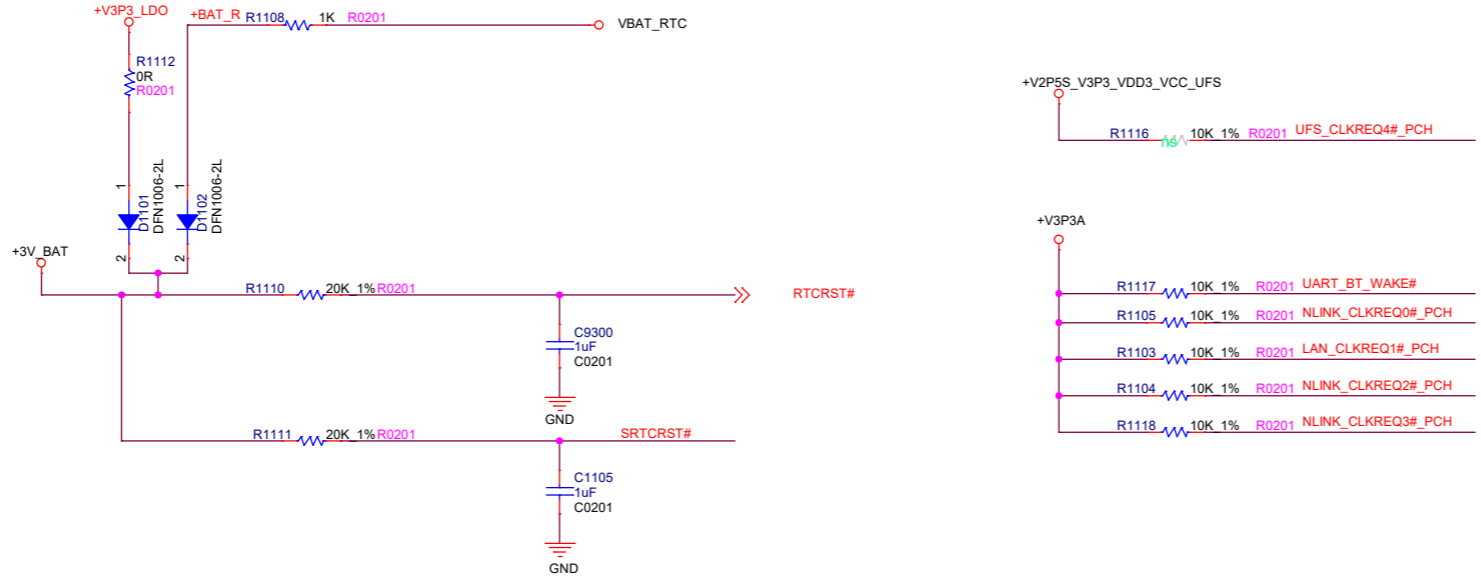
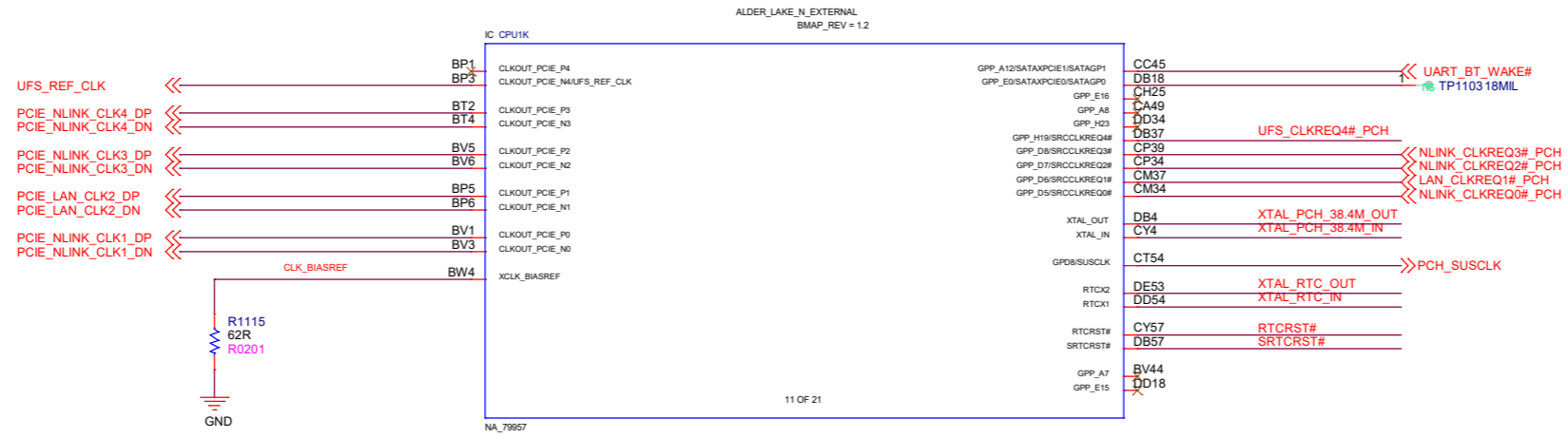

38.4MHZ

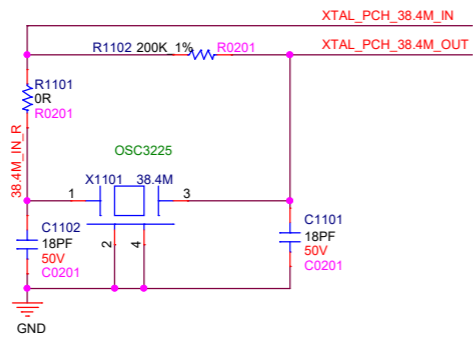

32.768KHZ

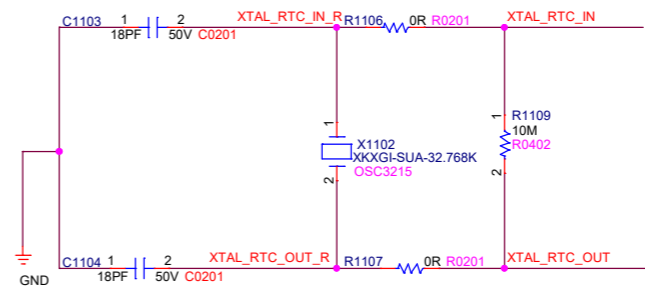

Namtso Technology Co., Ltd.			
Project:	A10-N305		
File:	ADL-N(Clock/RTC)		
Date:	Friday, February 02, 2024	Rev:	V12
Designed_by:	Victor.Chen	Sheet:	7

ADL-N(CSI/CNVI)

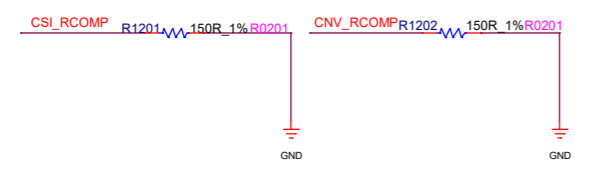
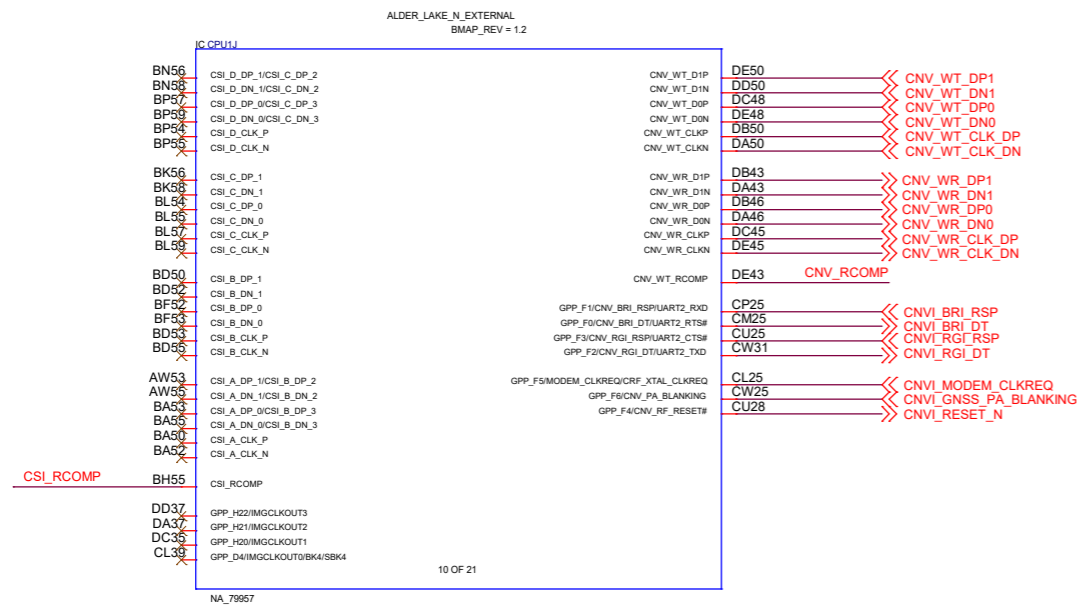

ADL-N(SYS/FIVR)

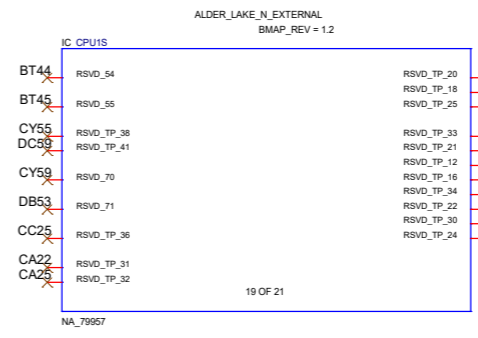
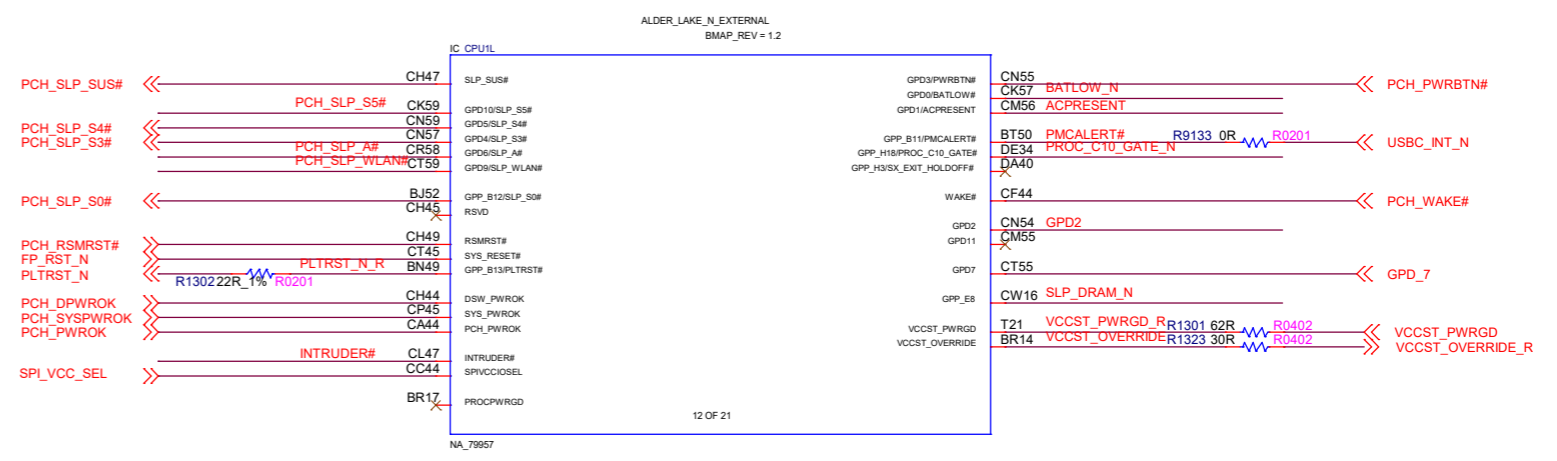

CONFIG RES

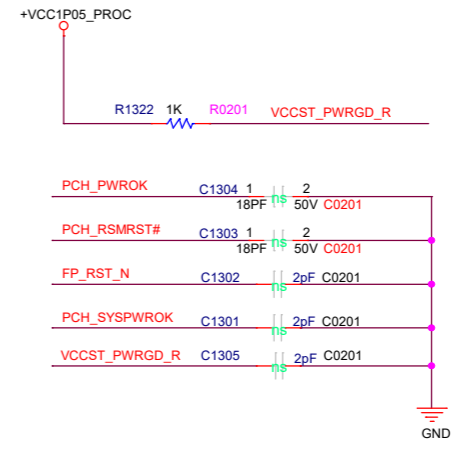
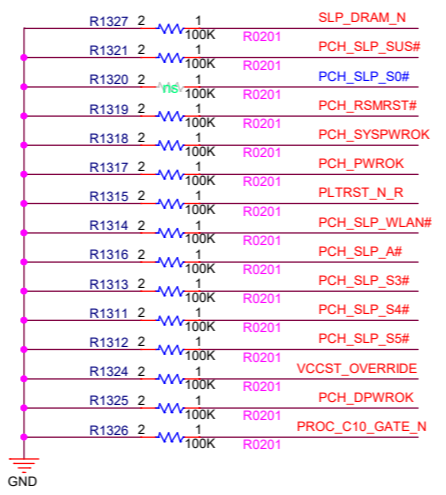
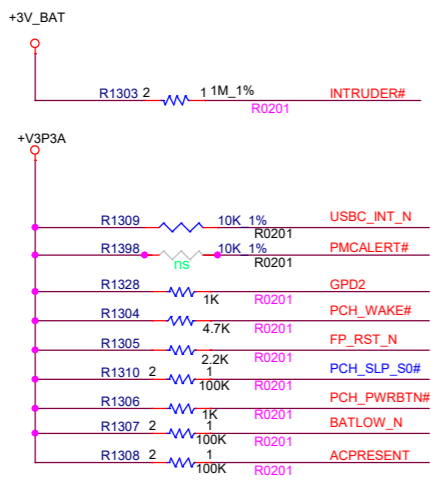

Namtso Technology Co., Ltd.			
Project:	A10-N305		
File:	ADL-N(CSI/CNVI)		
Date:	Friday, February 02, 2024	Rev:	V12
Designed_by:	Victor.Chen	Sheet:	8

ADL-N(MISC)

ADL-N(DEBUG/VALIDATION)

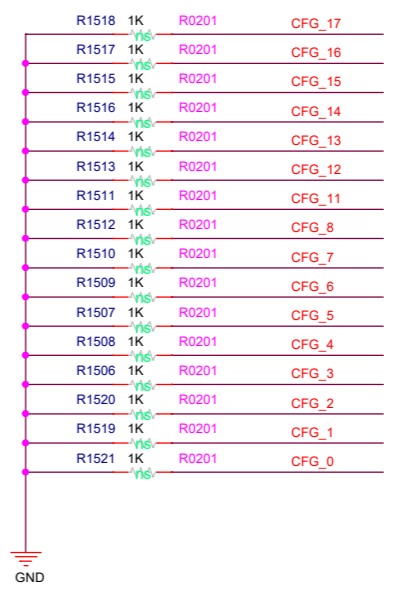
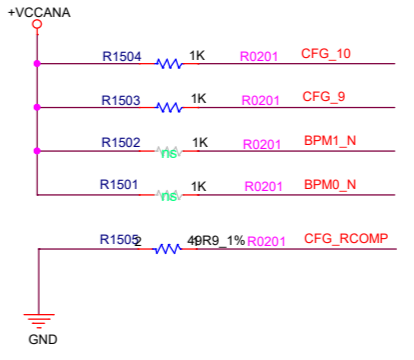
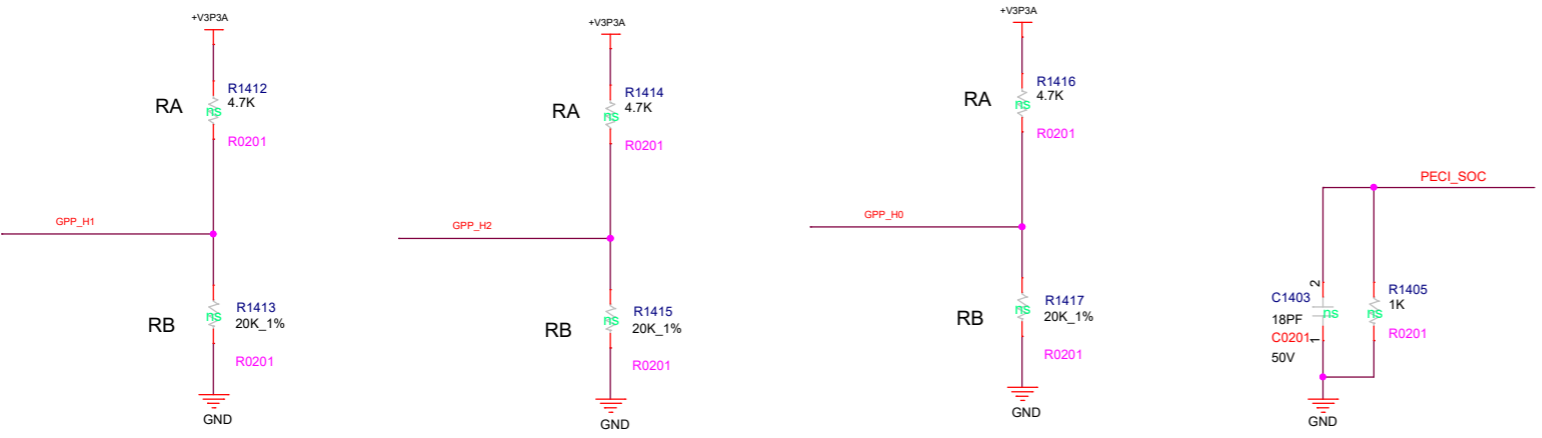
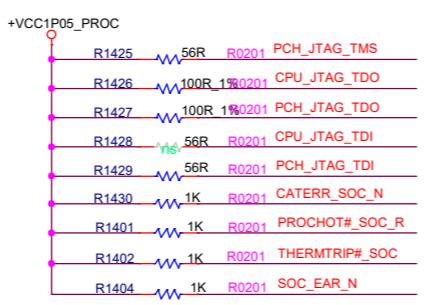
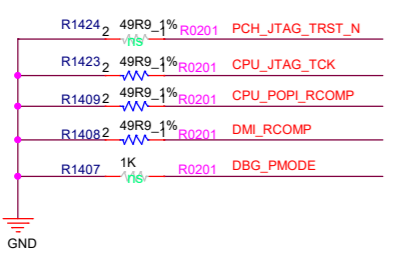
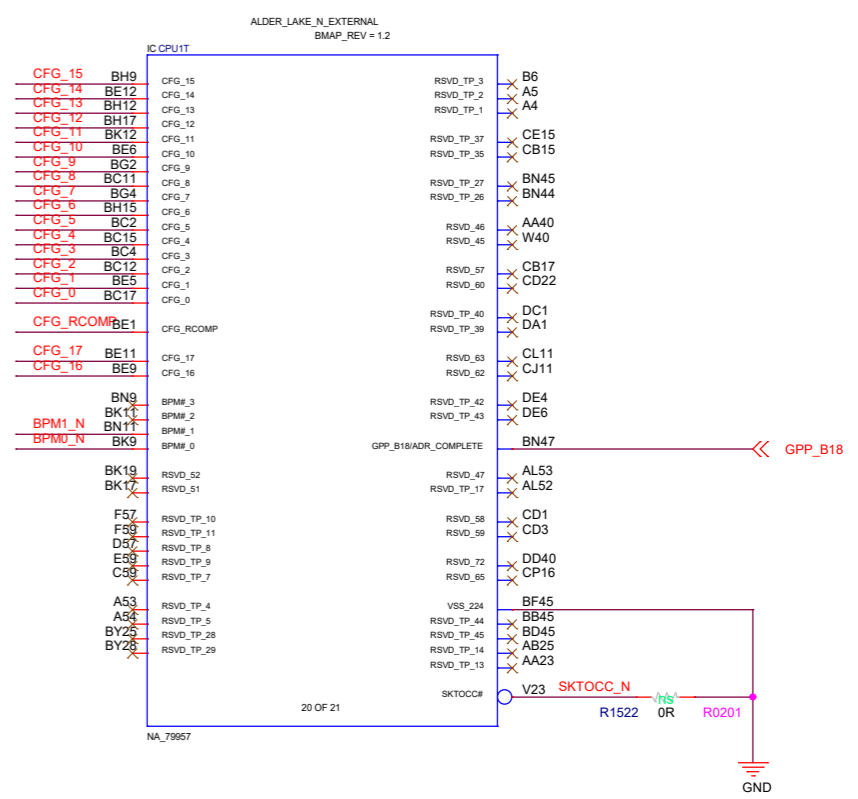
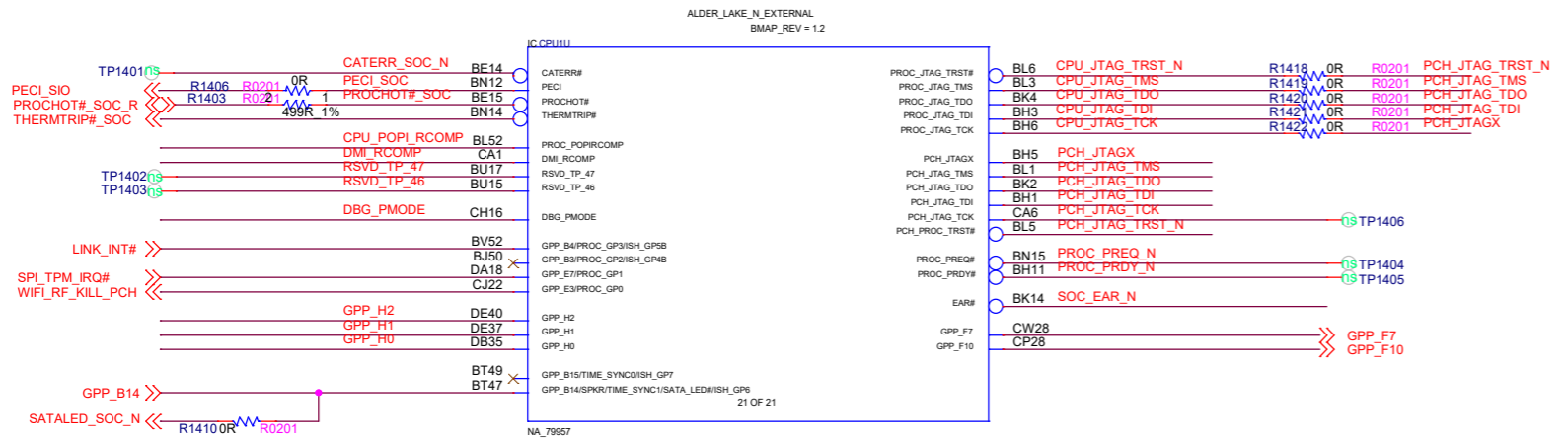

Namtsu Technology Co., Ltd.			
Project:	A10-N305		
File:	ADL-N(MISC)		
Date:	Friday, February 02, 2024	Rev:	V12
Designed_by:	Victor Chen	Sheet:	9

LPDDR5 CHA / CHB

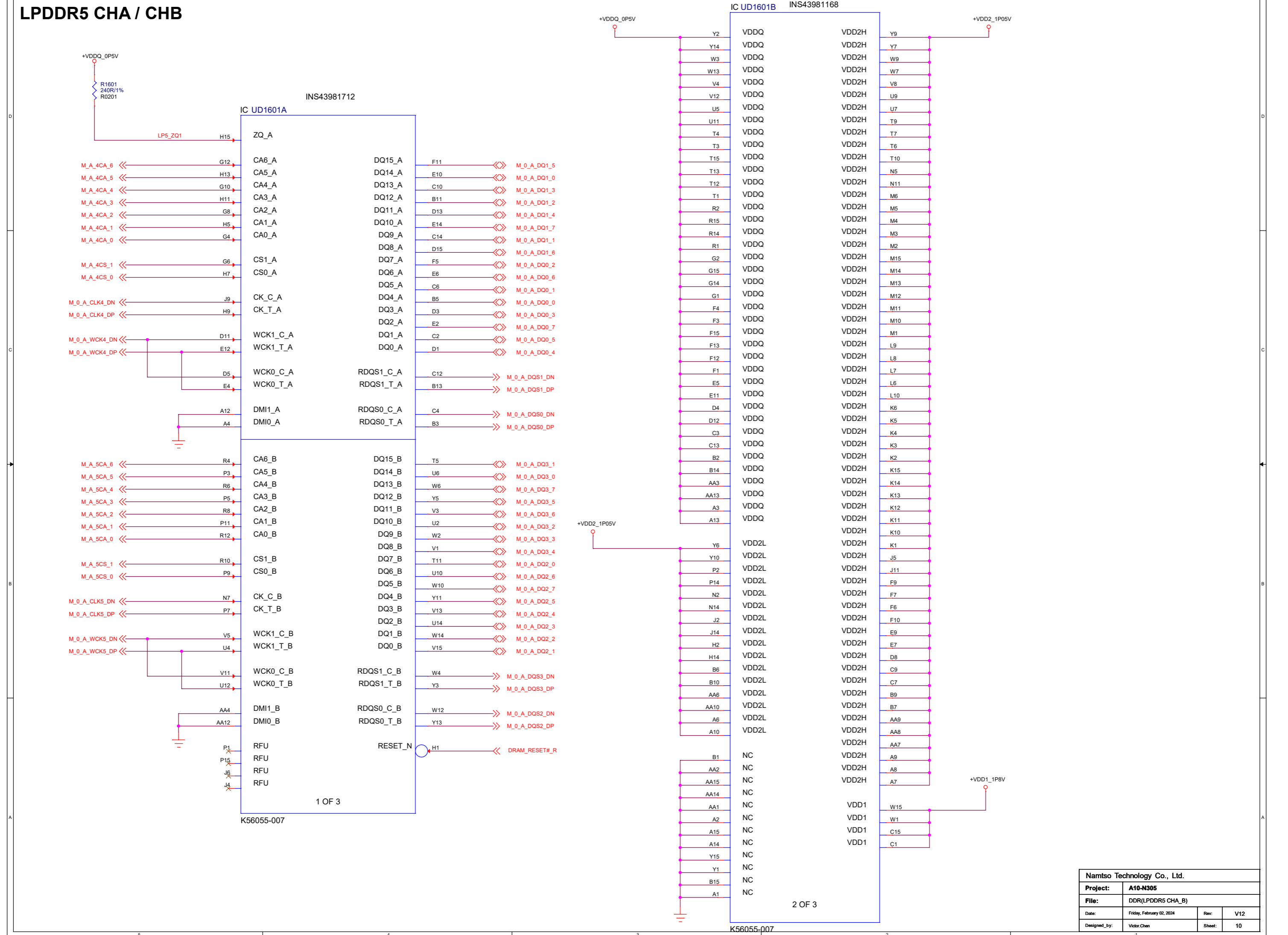

Namtso Technology Co., Ltd.			
Project:	A10-N305		
File:	DDR(LPDDR5 CHA_B)		
Date:	Friday, February 02, 2024	Rev:	V12
Designed_by:	Victor Chen	Sheet:	10

LPDDR5 CHC / CHD

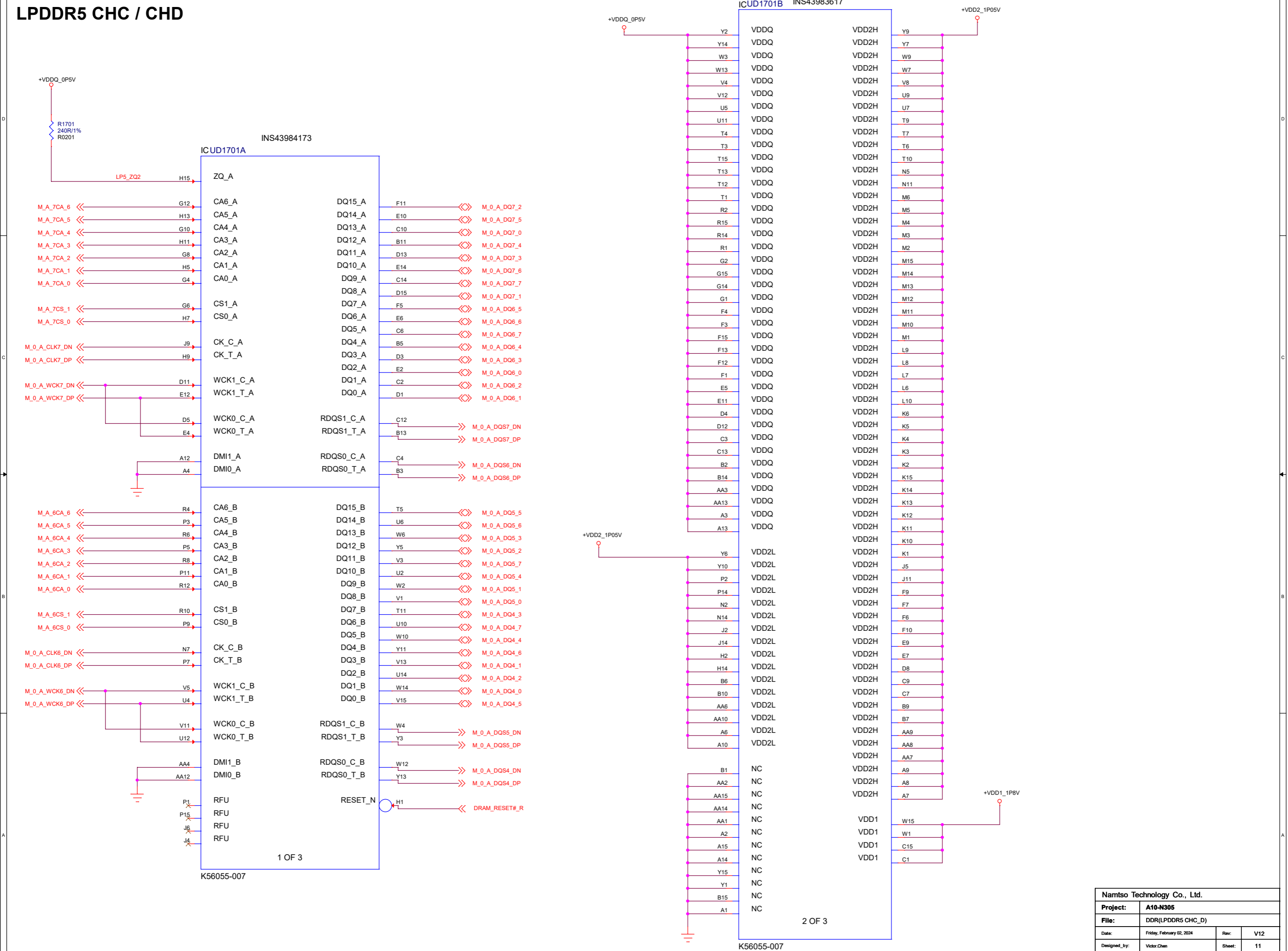

Namtso Technology Co., Ltd.			
Project:	A10-N305		
File:	DDR(LPDDR5 CHC_D)		
Date:	Friday, February 02, 2024	Rev:	V12
Designed_by:	Victor Chen	Sheet:	11

LPDDR5 CAP/GND

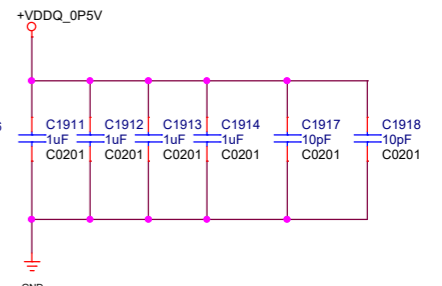
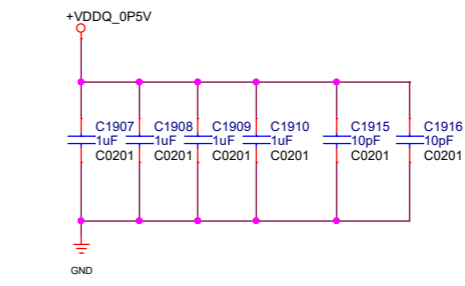
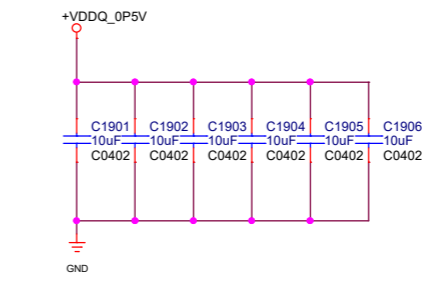
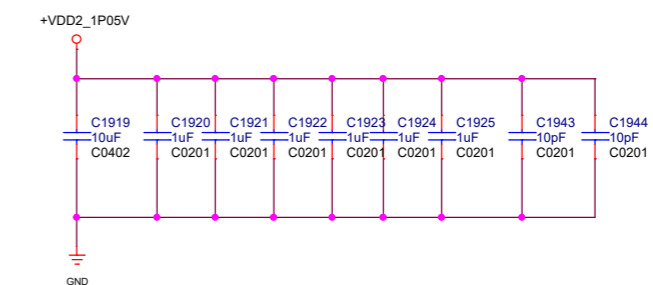
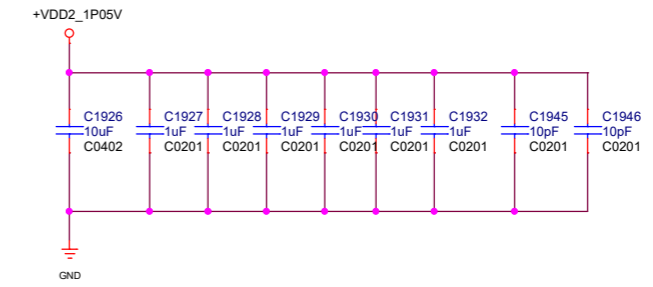
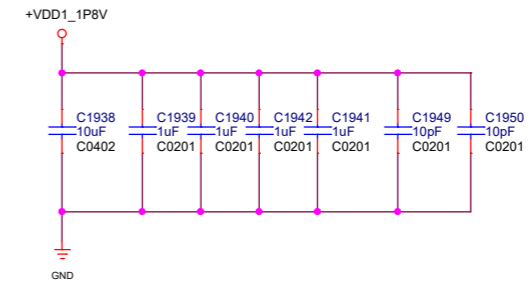
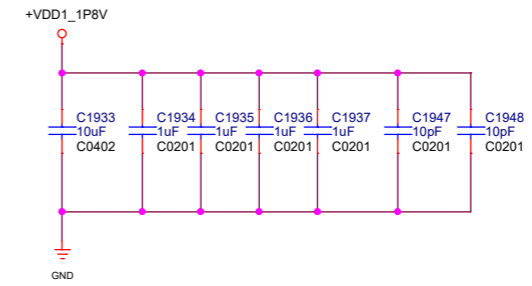
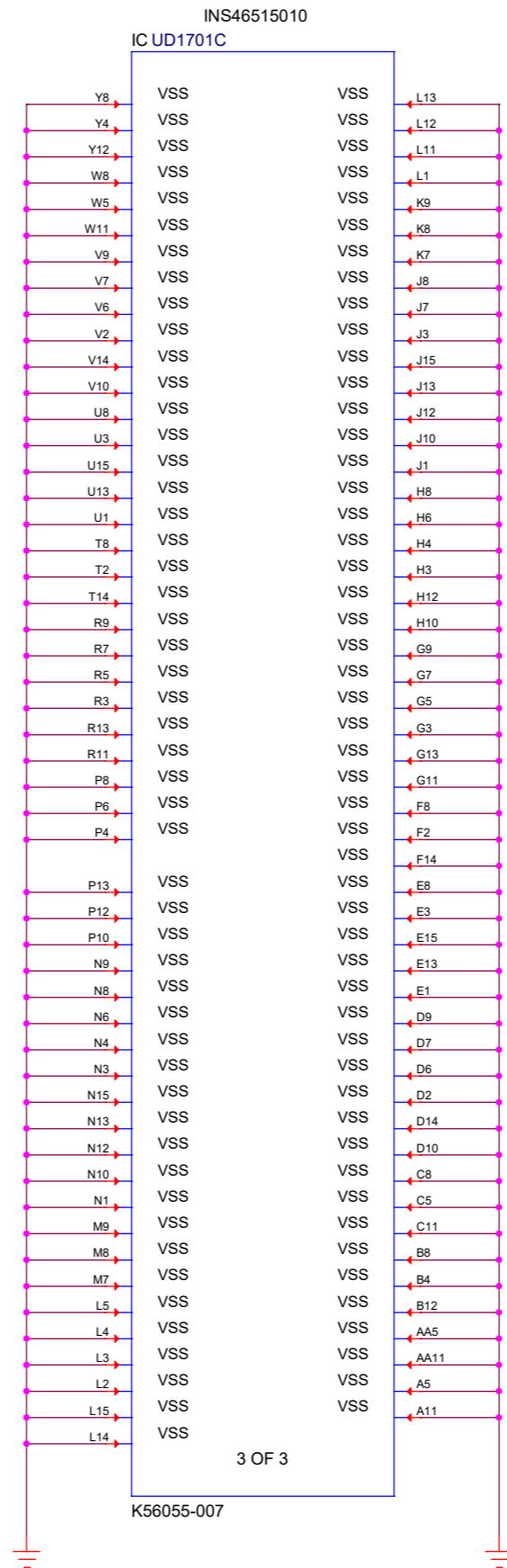
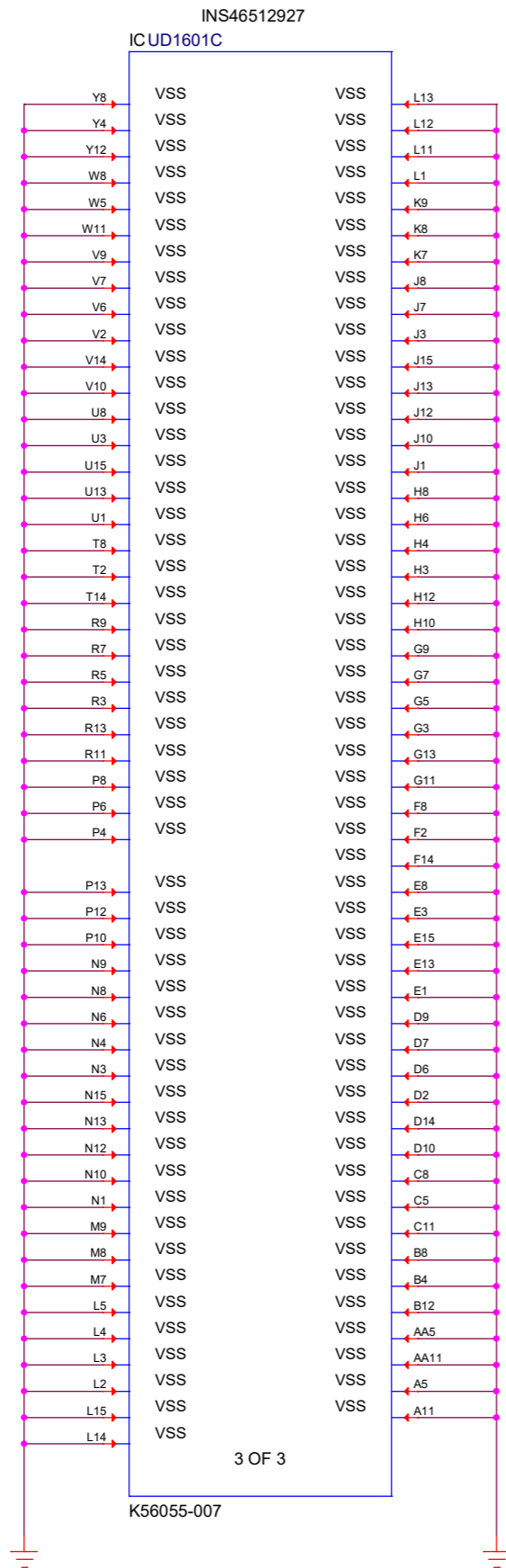

Namtso Technology Co., Ltd.			
Project:	A10-N305		
File:	DDR(LPDDR5 CHC_D)		
Date:	Friday, February 02, 2024	Rev:	V12
Designed_by:	Victor Chen	Sheet:	12

ADL-N(Power_Core)

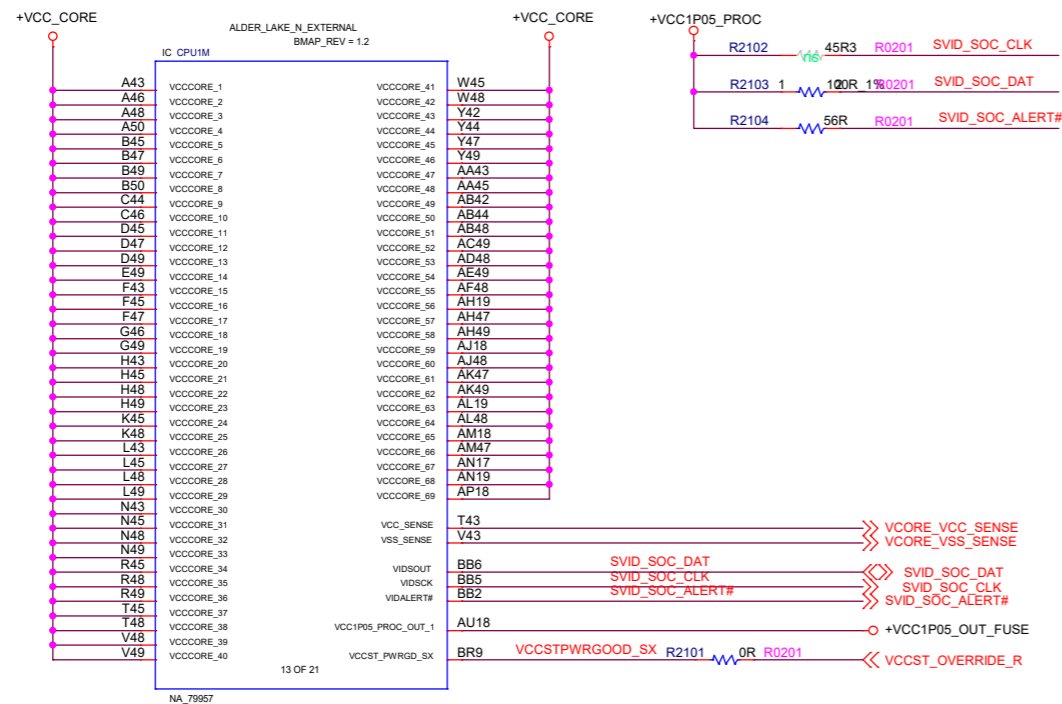

DDR(SMBUS)

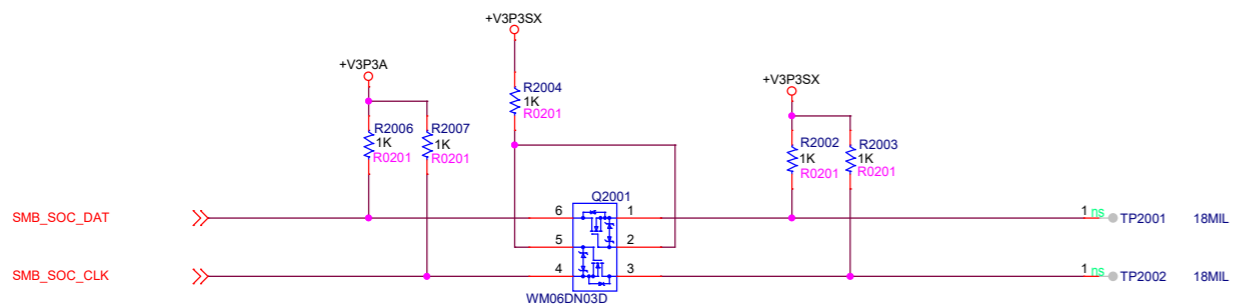

ADL-N(PowerCAP_Core)

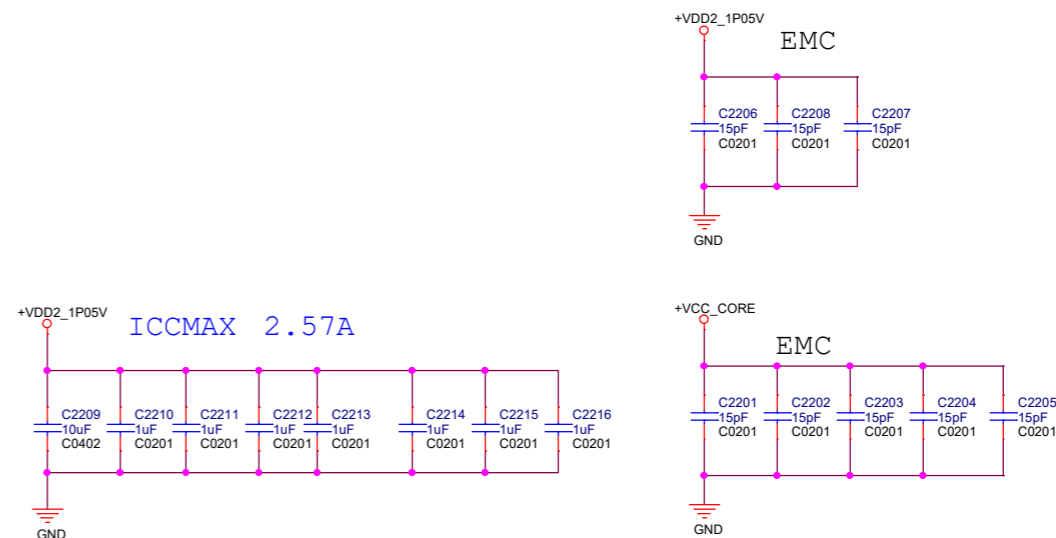

Namtso Technology Co., Ltd.			
Project:	A10-N305		
File:	ADL-N(Power_Core)		
Date:	Friday, February 02, 2024	Rev:	V12
Designed_by:	Victor Chen	Sheet:	13

ADL-N(Power_PCH)

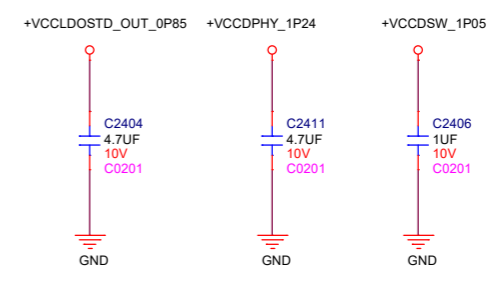
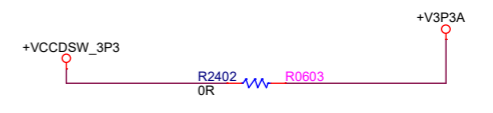
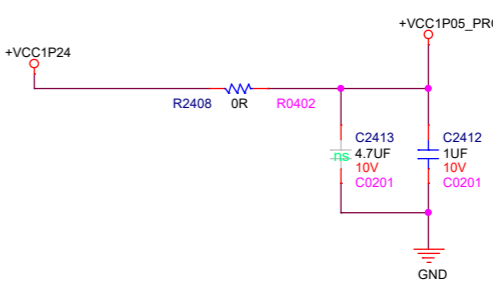
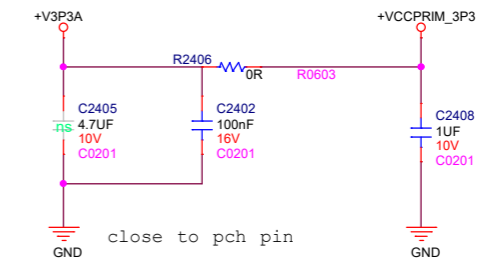
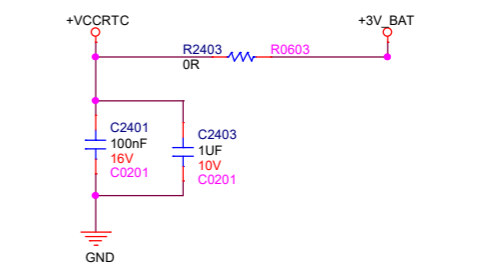
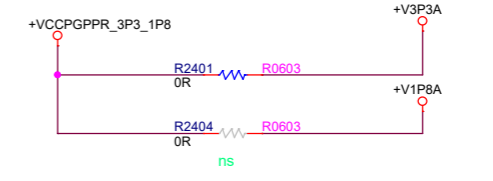
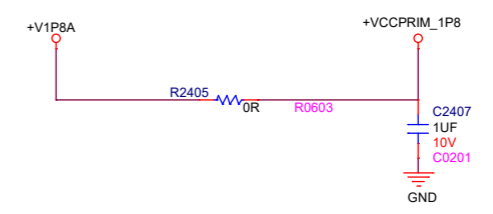
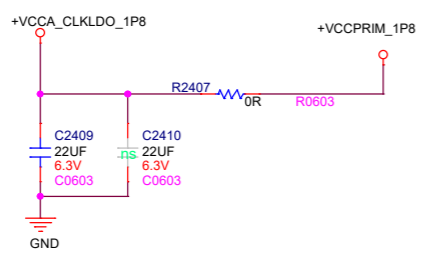
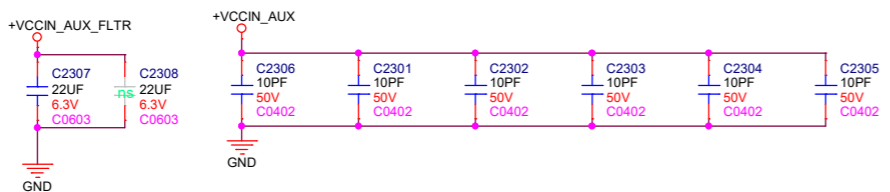
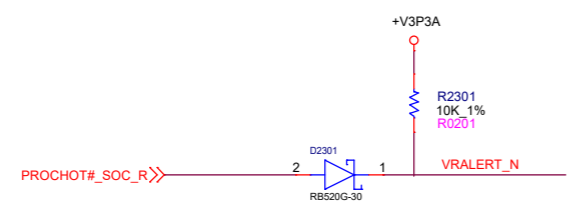
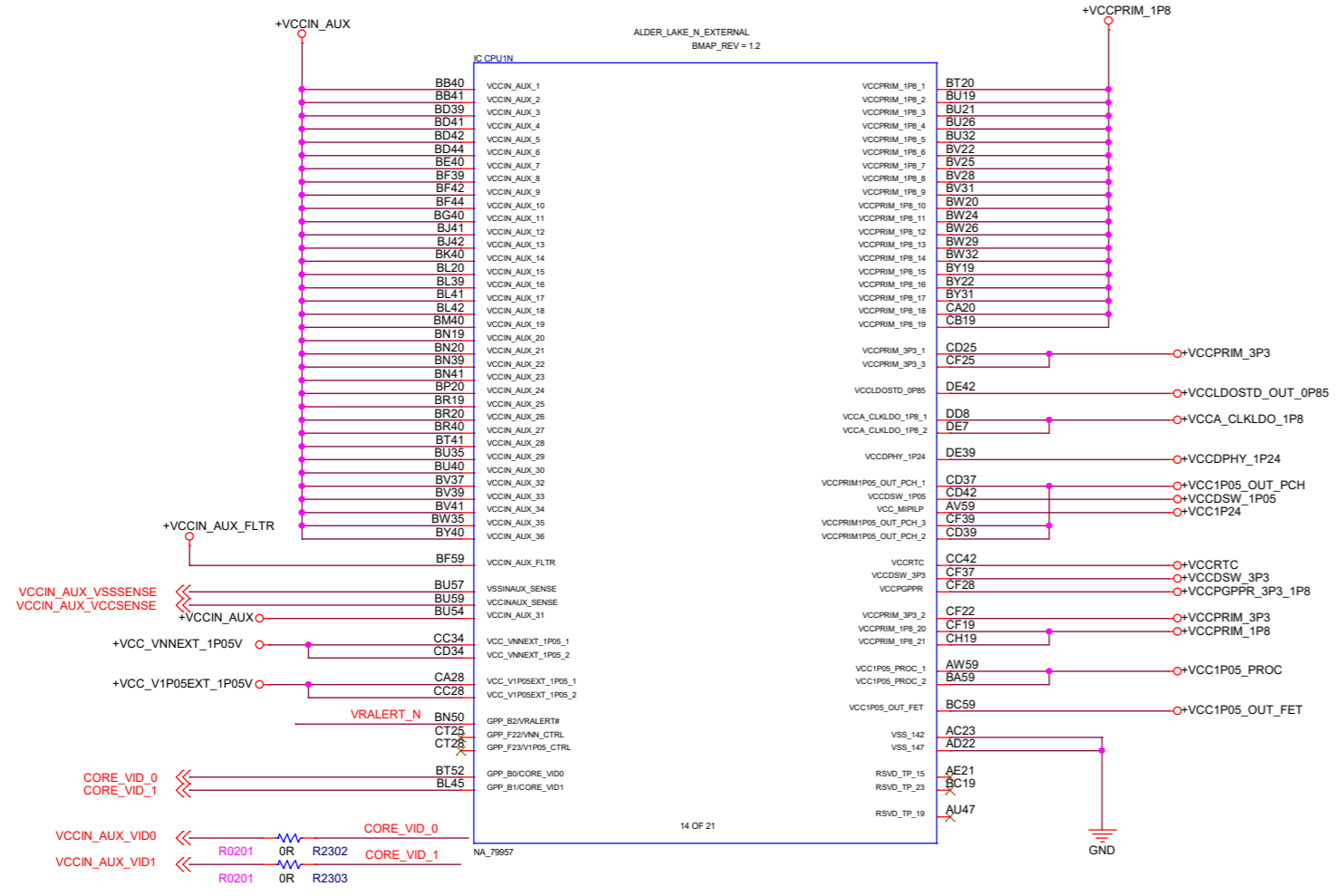

Namtso Technology Co., Ltd.			
Project:	A10-N305		
File:	ADL-N(Power_PCH)		
Date:	Friday, February 02, 2024	Rev:	V12
Designed_by:	Victor.Chen	Sheet:	14

ADL-N(Power VSS)

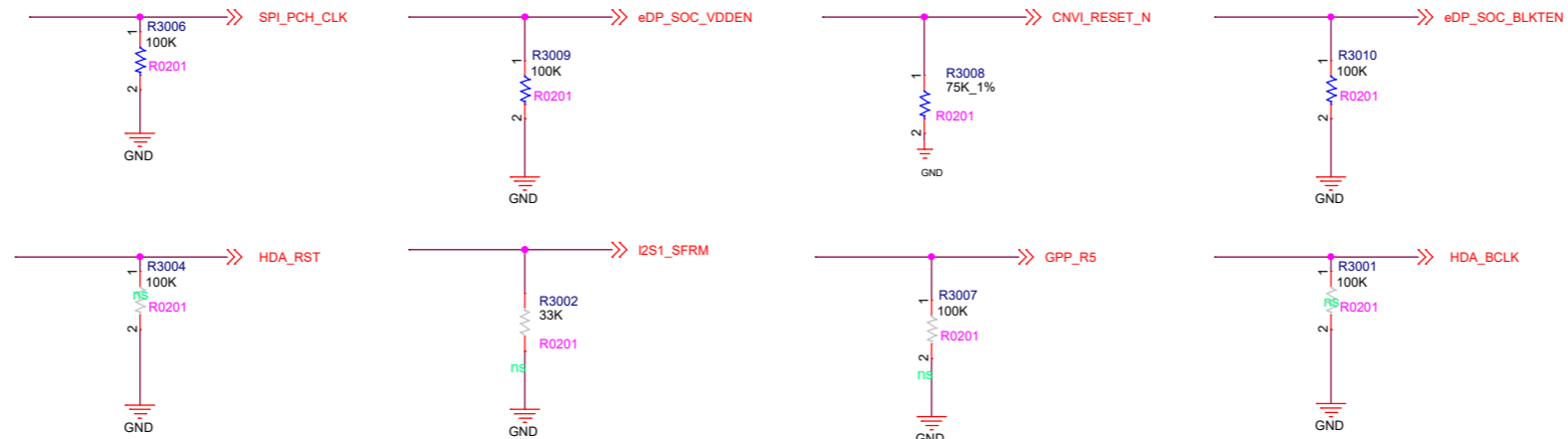
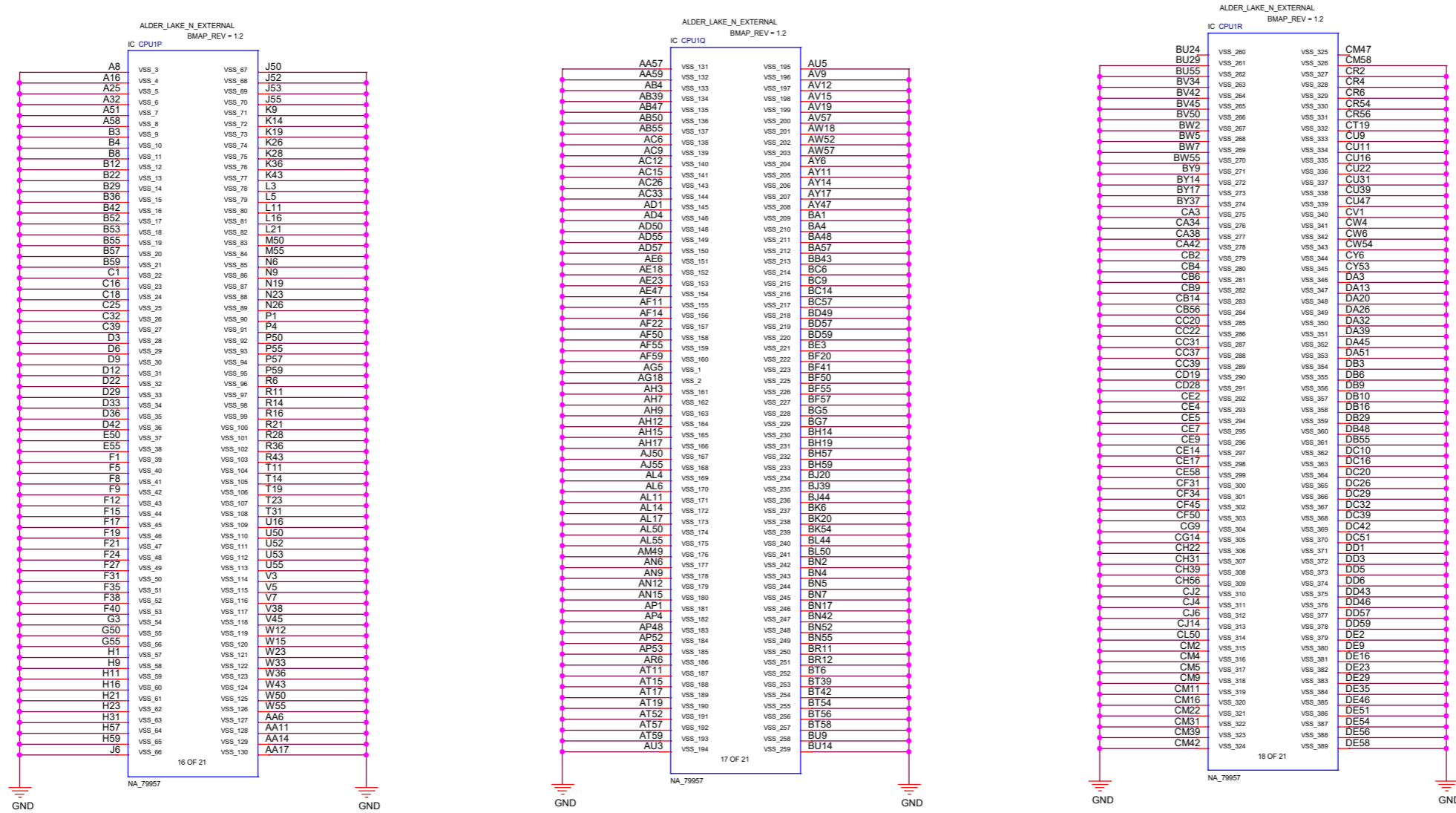

Namtso Technology Co., Ltd.			
Project:	A10-N305		
File:	ADL-N(Power VSS)		
Date:	Friday, February 02, 2024	Rev:	V12
Designed_by:	Victor.Chen	Sheet:	15

DISCHAGE

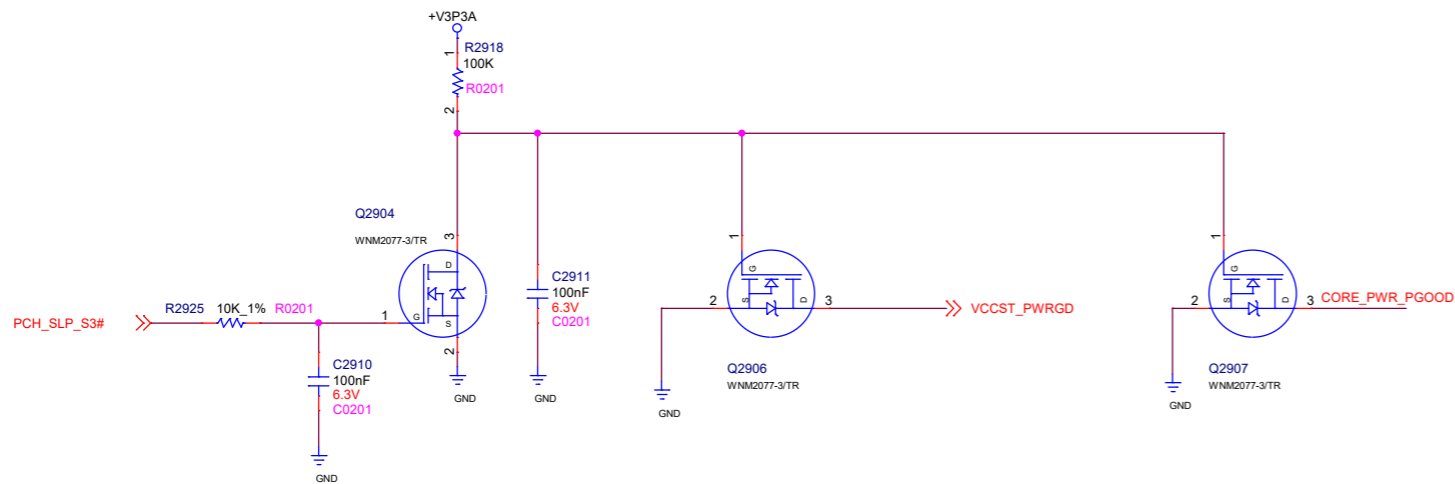

VR_Ready Sequence Control Ckts PCH_SYSPWROK Sequence Control Ckts

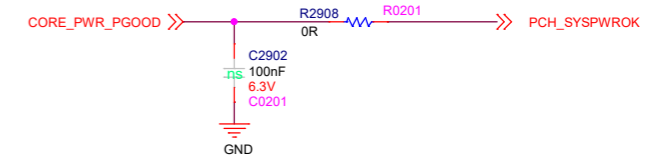

RSMRST# Sequence Control Ckts

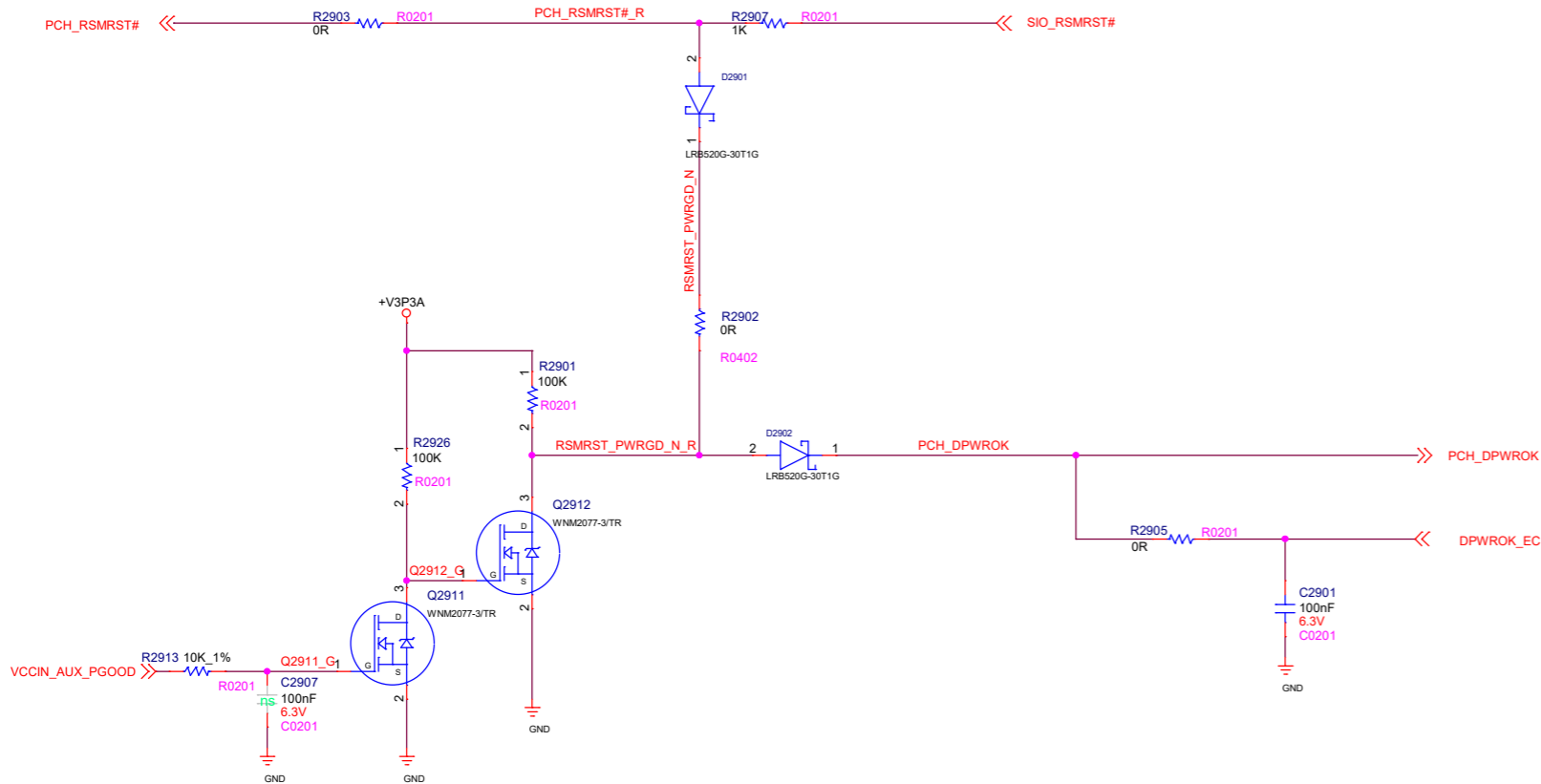

PCH_PWRGD & VCCST_PWRGD Sequence Control Ckts

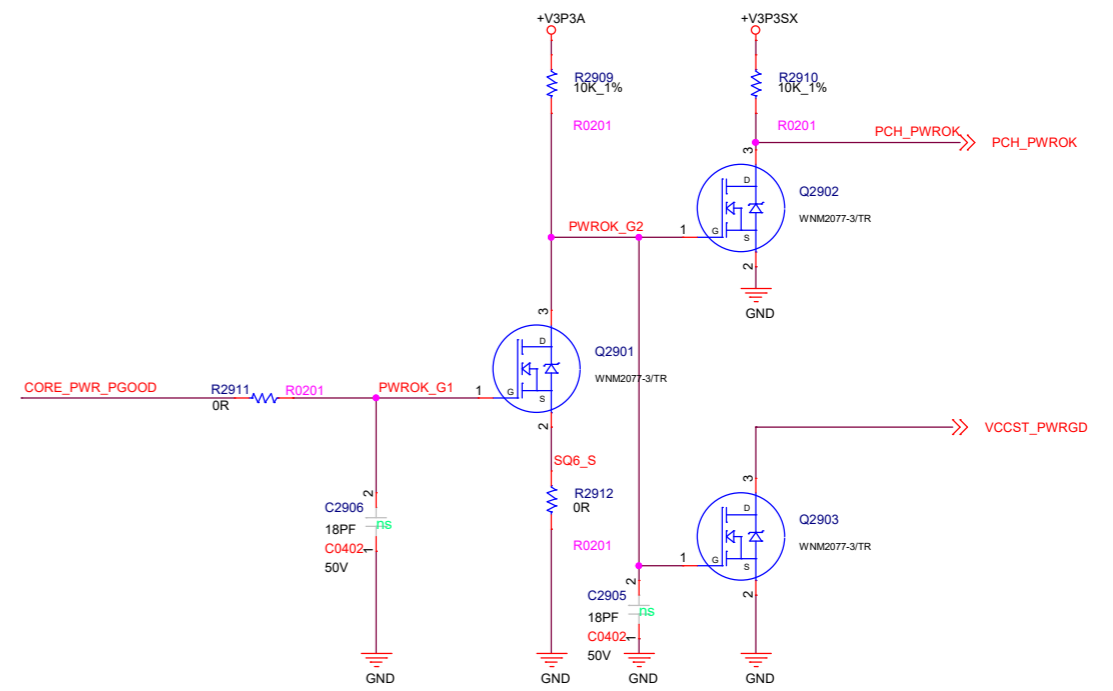

Namtso Technology Co., Ltd.			
Project:	A10-N305		
File:	ADL-N(Sequence)		
Date:	Friday, February 02, 2024	Rev:	V12
Designed_by:	Victor Chen	Sheet:	16

STRAP PIN

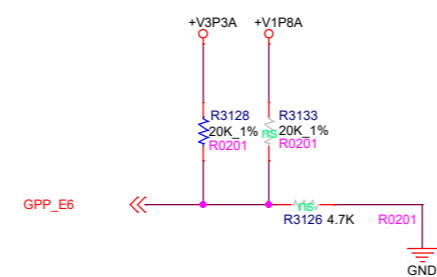
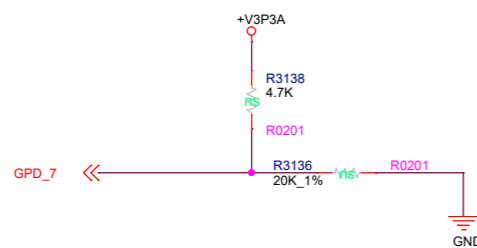
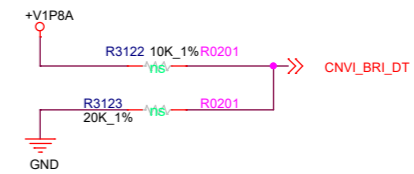
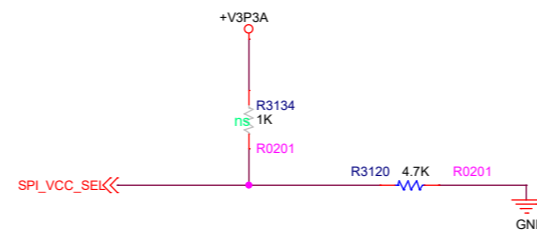
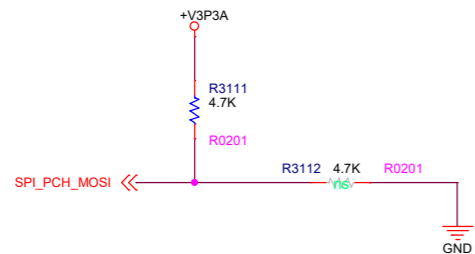
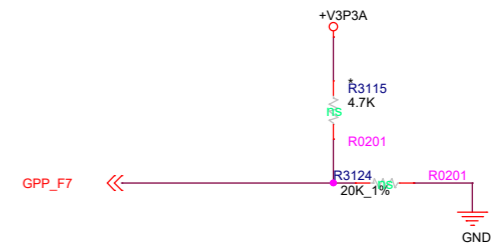
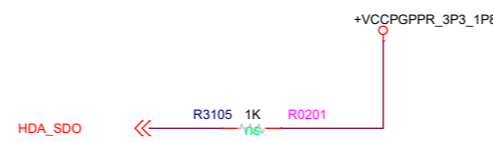
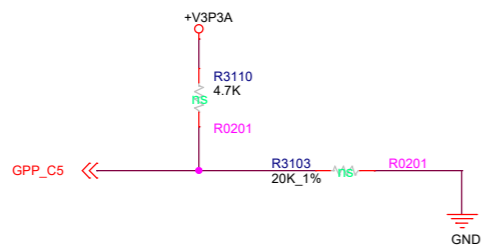
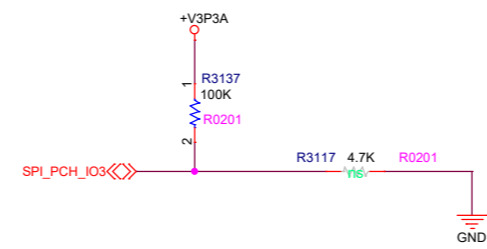
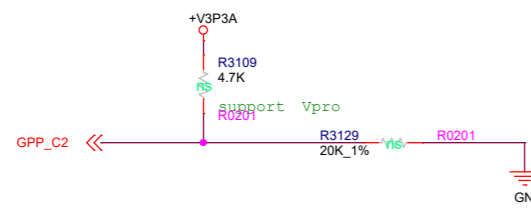
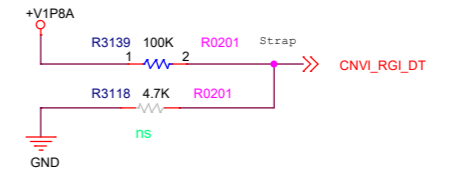
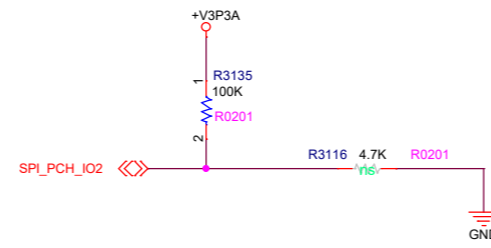
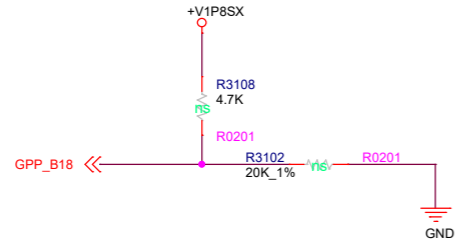
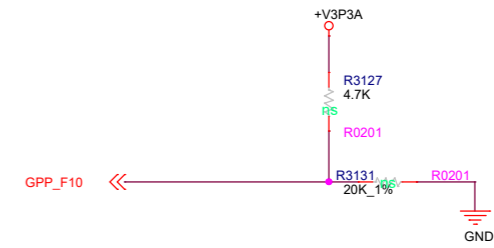
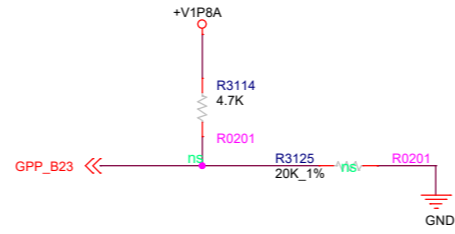
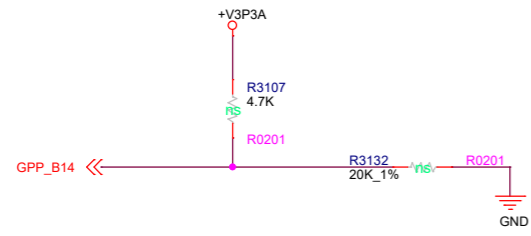

Namtso Technology Co., Ltd.			
Project:	A10-N305		
File:	ADL-N(STRAP)		
Date:	Friday, February 02, 2024	Rev:	V12
Designed_by:	Victor Chen	Sheet:	17

SUPER IO

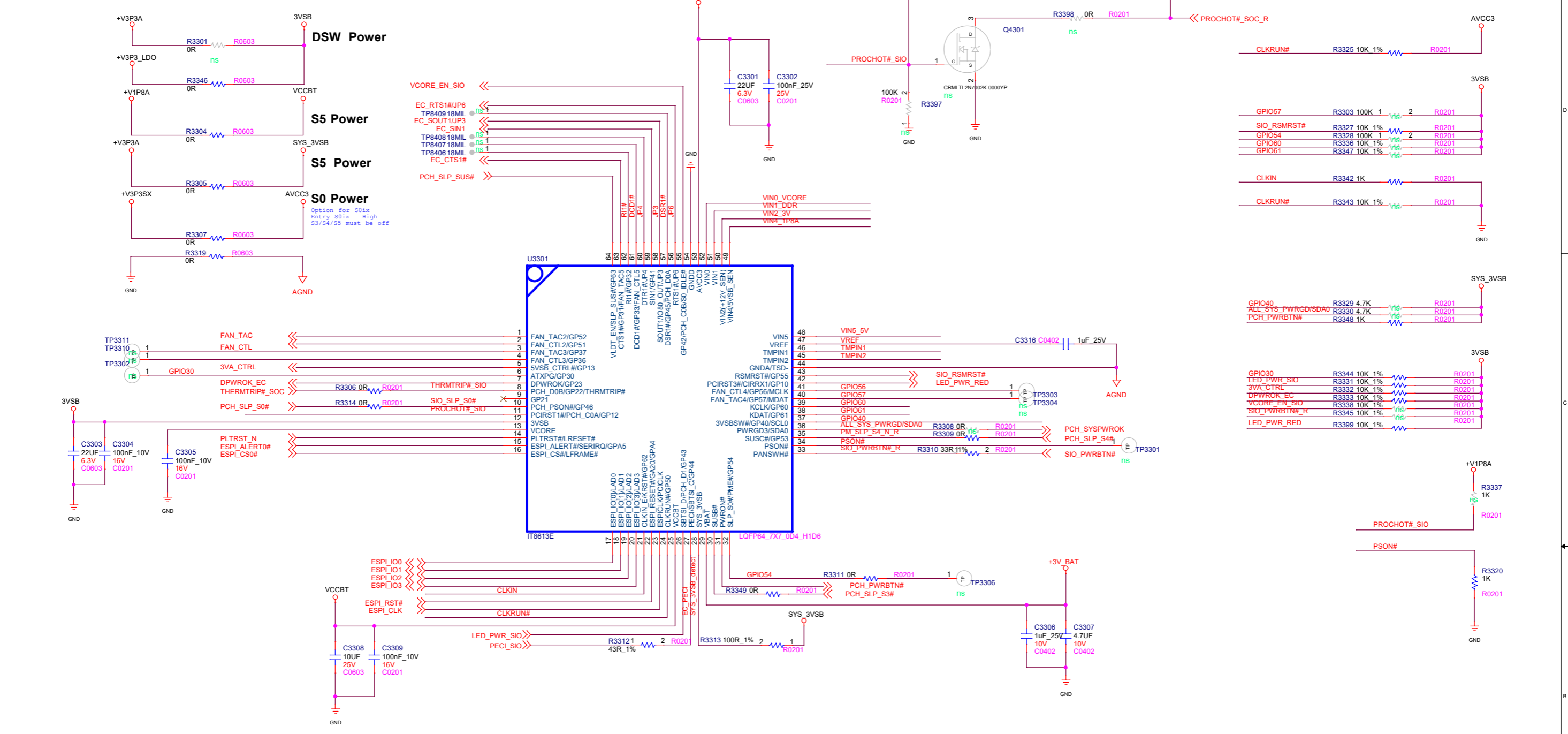

Thermal Sensor

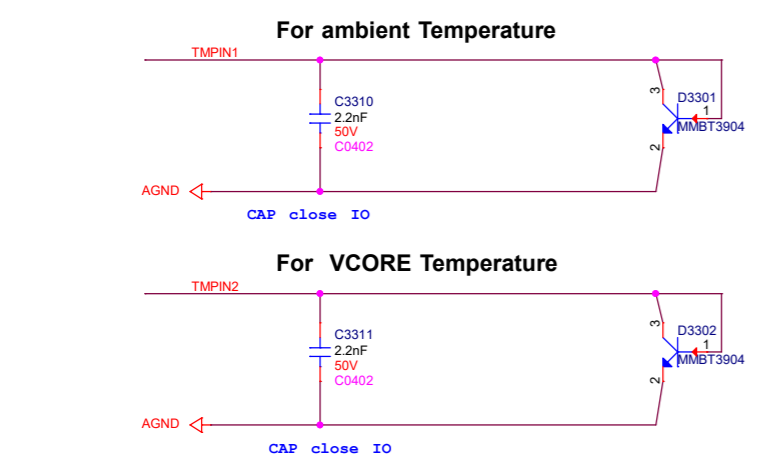

EC Poweron Strapping

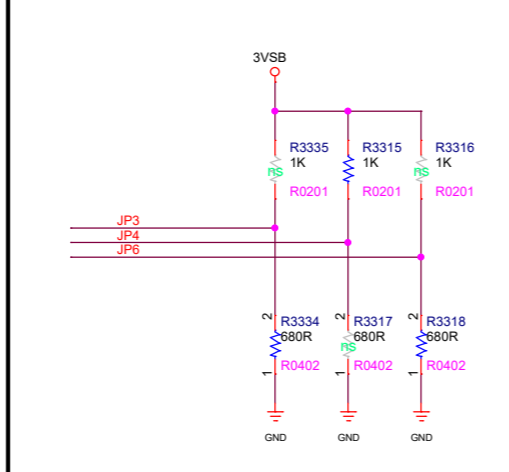

Voltage Monitor

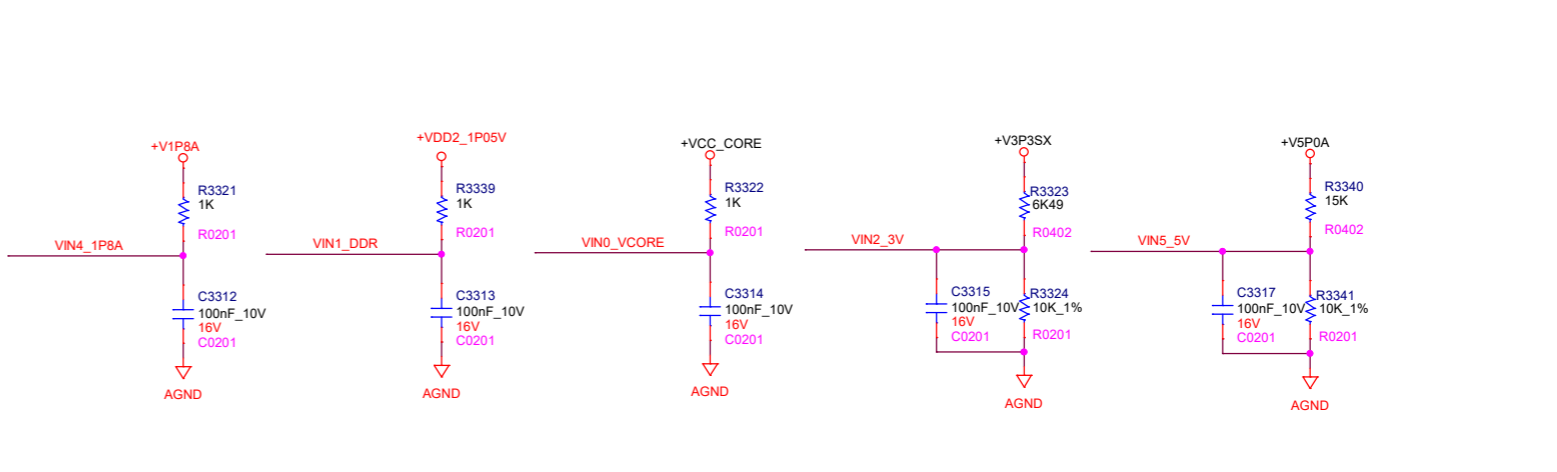

Namsco Technology Co., Ltd.			
Project:	A10-N305		
File:	SIO(ITE8613E_Non DSW)		
Date:	Friday, February 02, 2024	Rev:	V12
Designed_by:	Victor Chen	Sheet:	18

HDMI Power

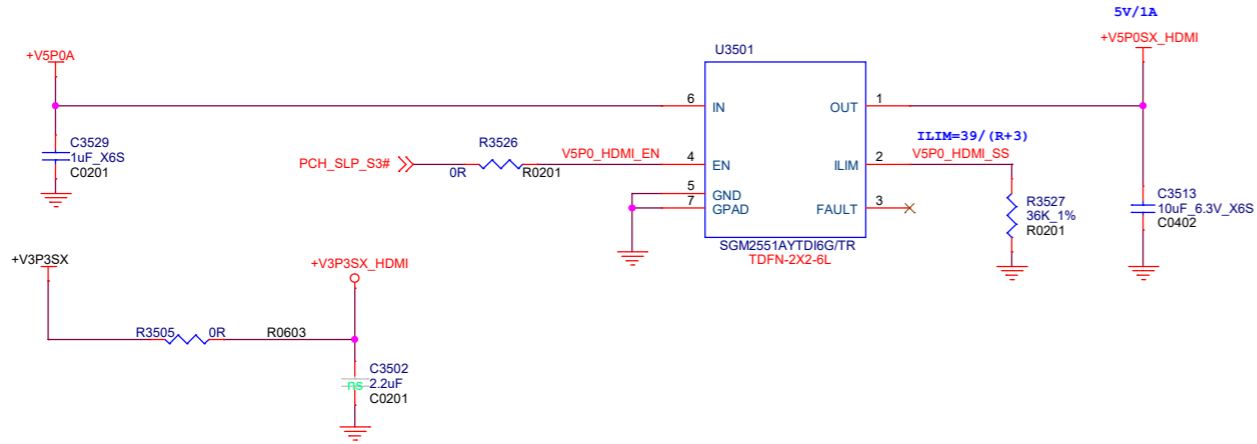

HDMI LF

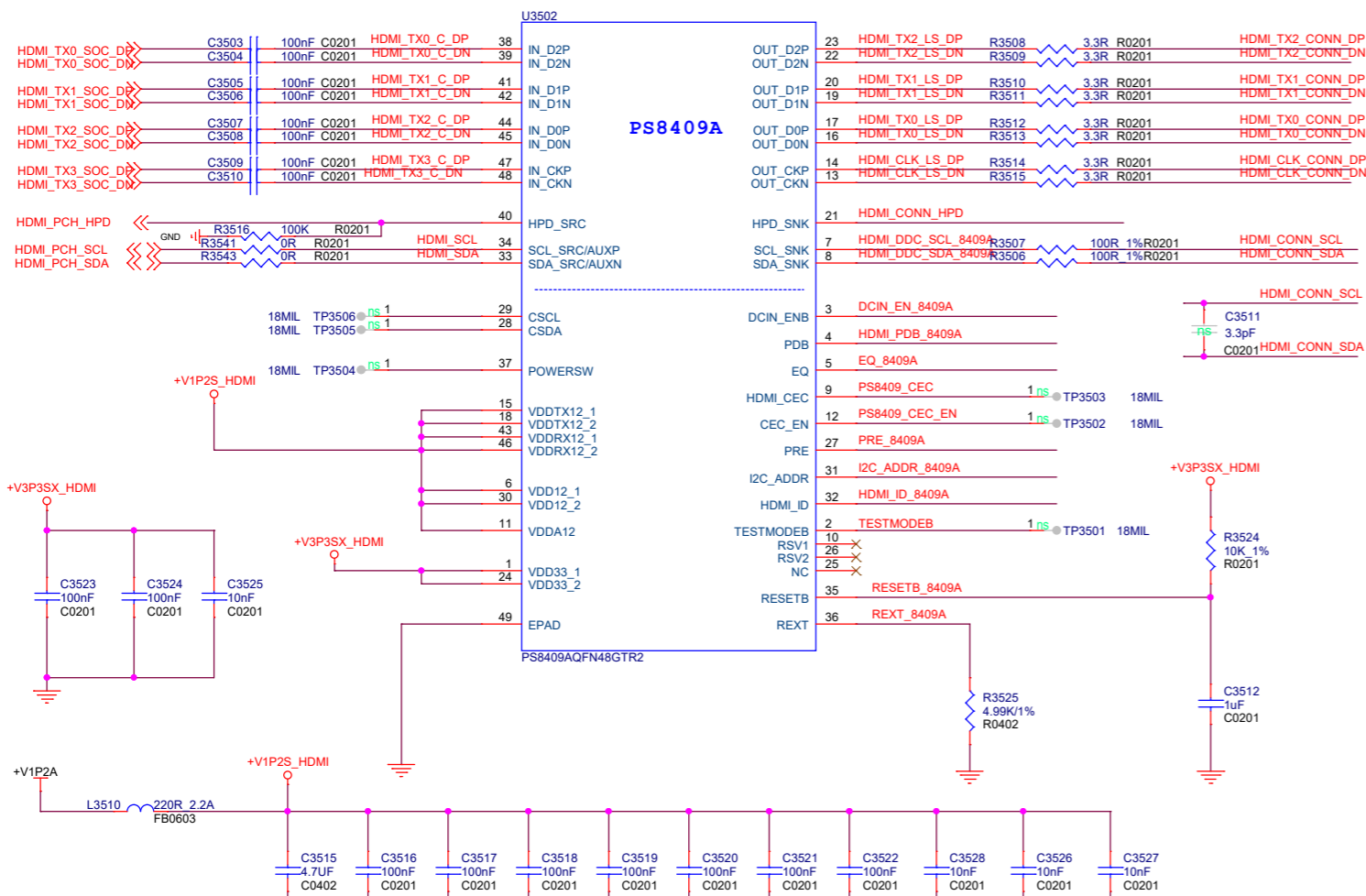

HDMI CONN

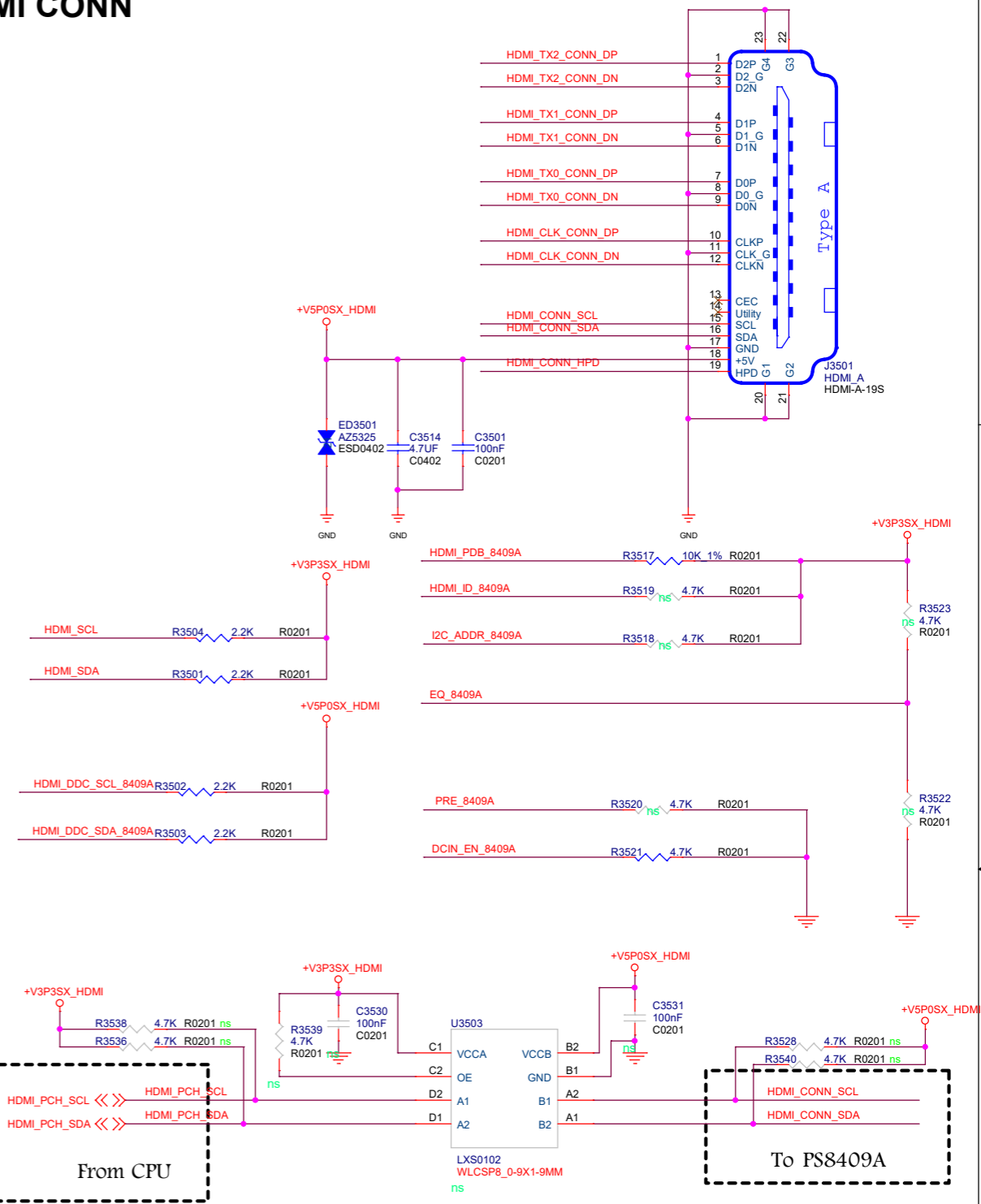

HDMI ESD

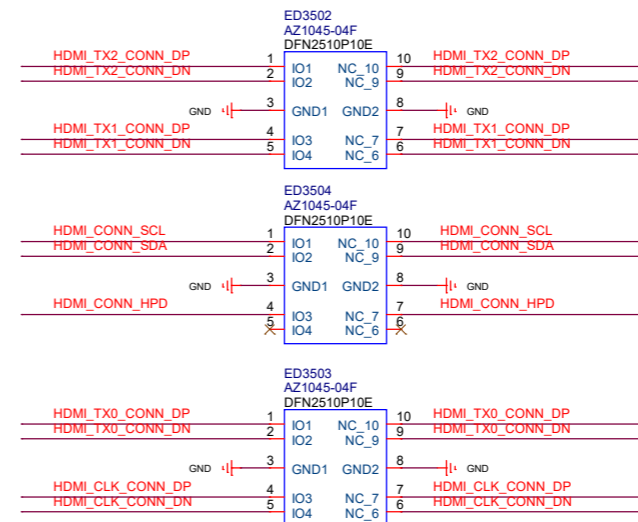

Namtso Technology Co., Ltd.			
Project:	A10-N305		
File:	Display(HDMI 2.0)		
Date:	Friday, February 02, 2024	Rev:	V12
Designed_by:	Victor Chen	Sheet:	19

SPI FLASH

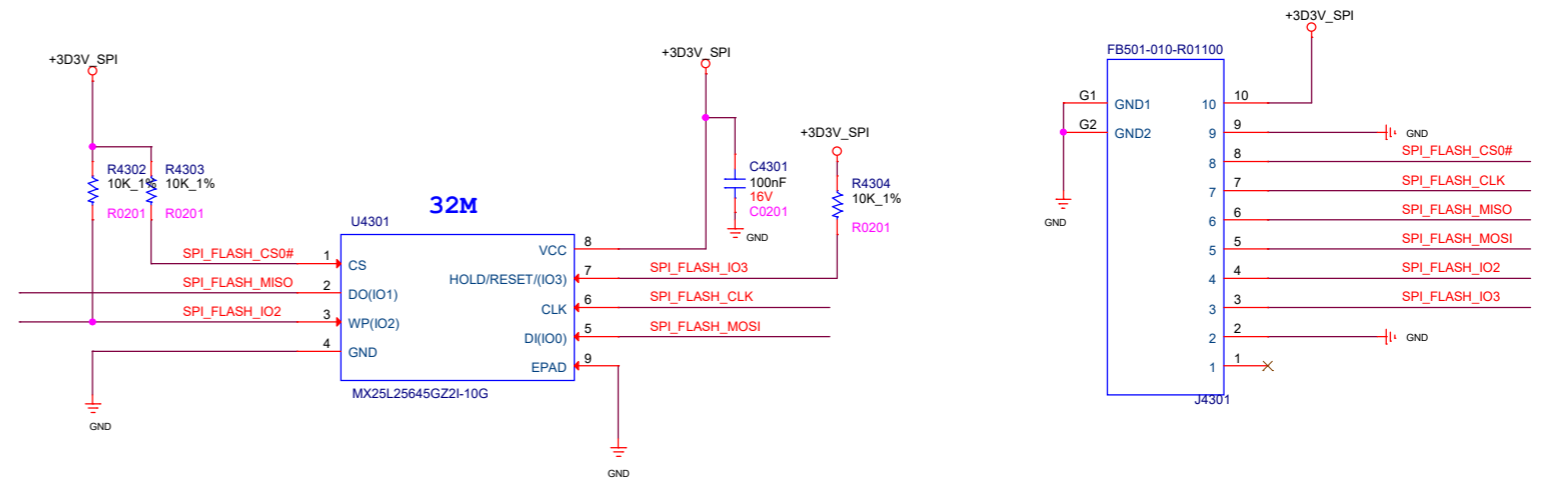
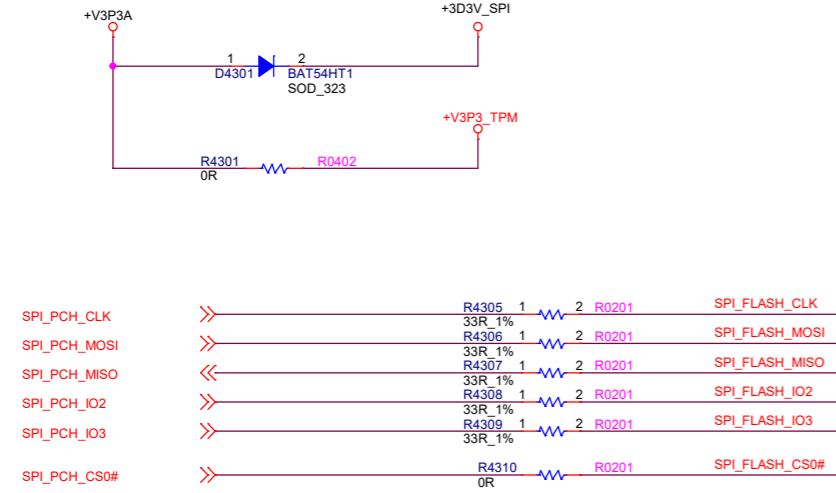

TPM

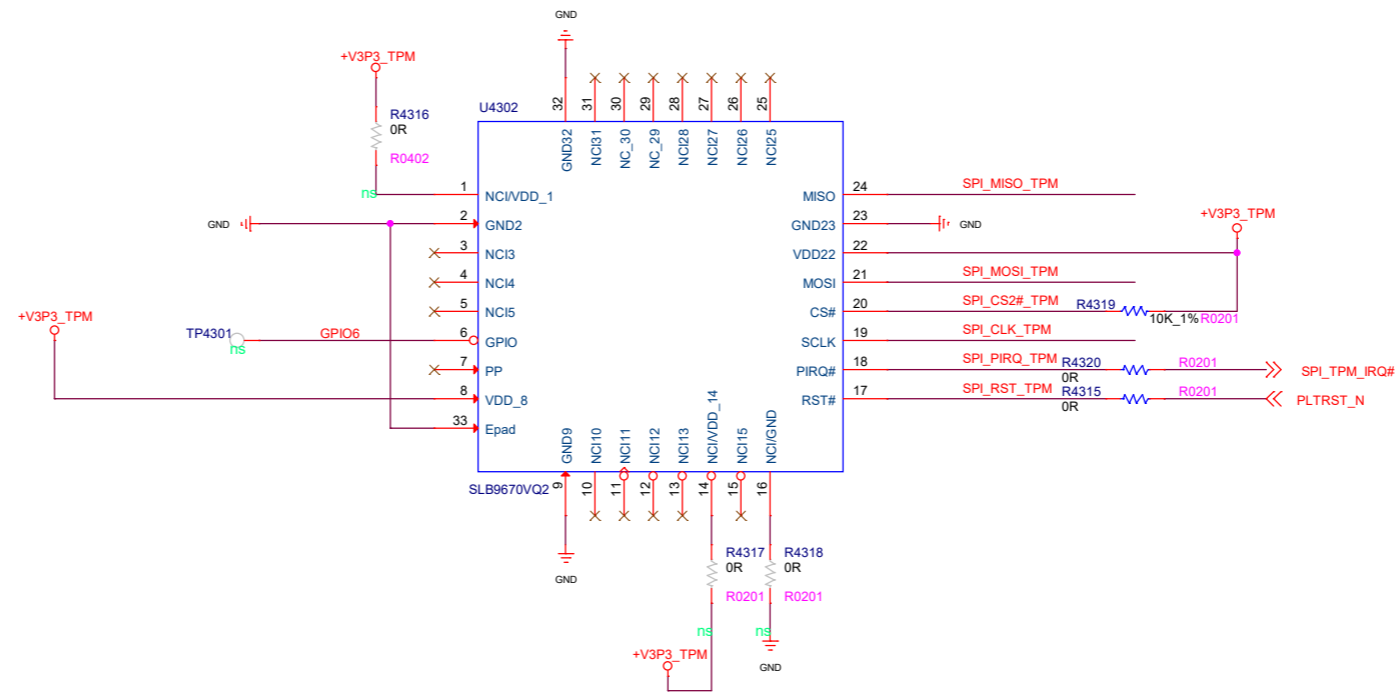
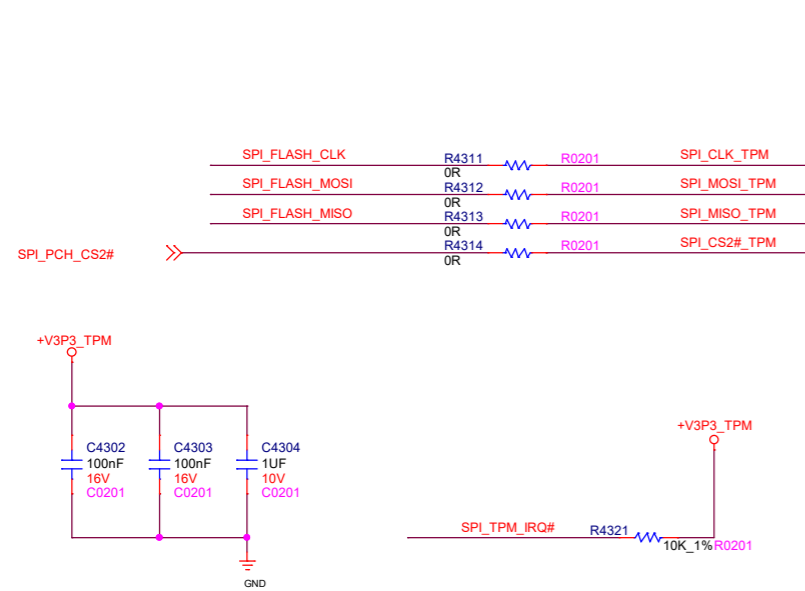

Namtso Technology Co., Ltd.			
Project:	A10-N305		
File:	Storage(BIOS & TPM)		
Date:	Friday, February 02, 2024	Rev:	V12
Designed_by:	Victor Chen	Sheet:	20

Storage(USB TO SPI)

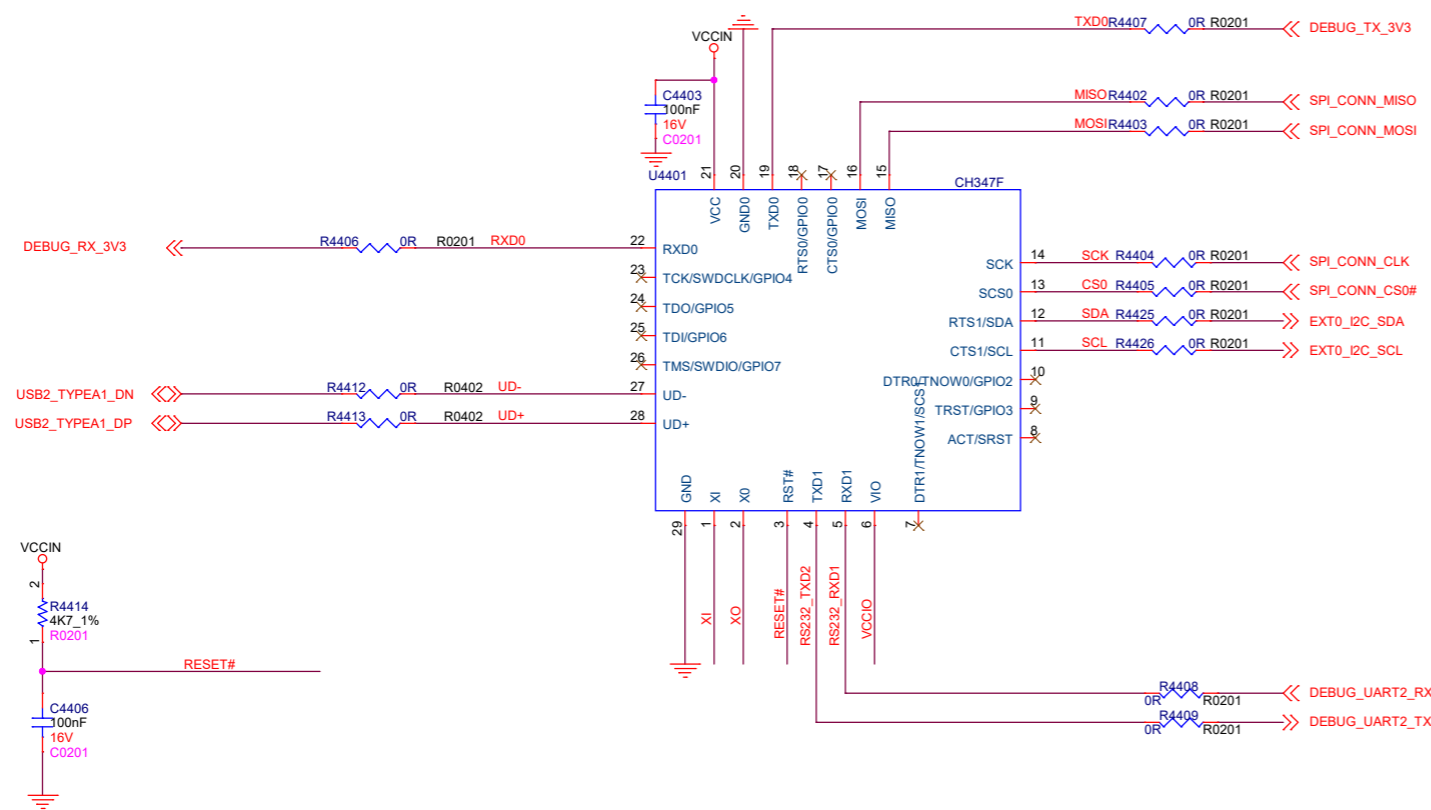

Bypass Caps

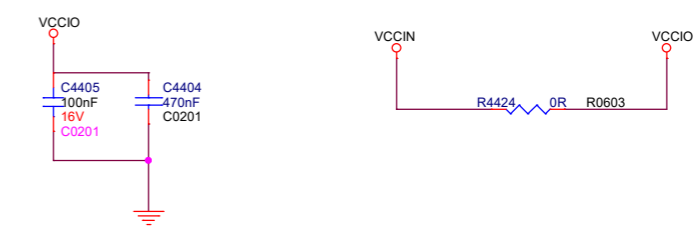

Crystal 8MHZ

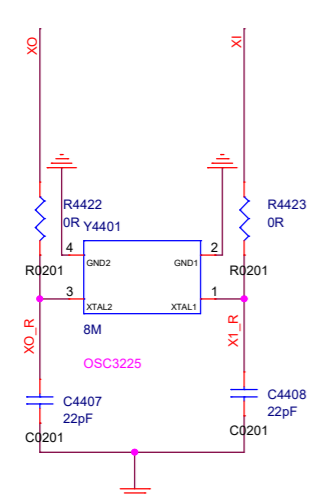

SPI Pull High Res

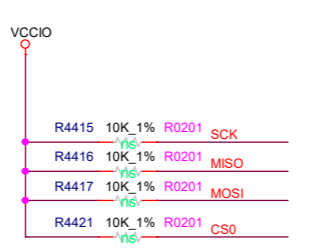

Reserve I2C

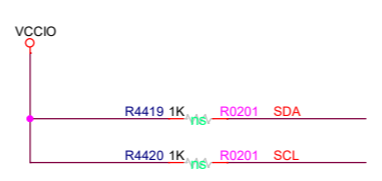

Power

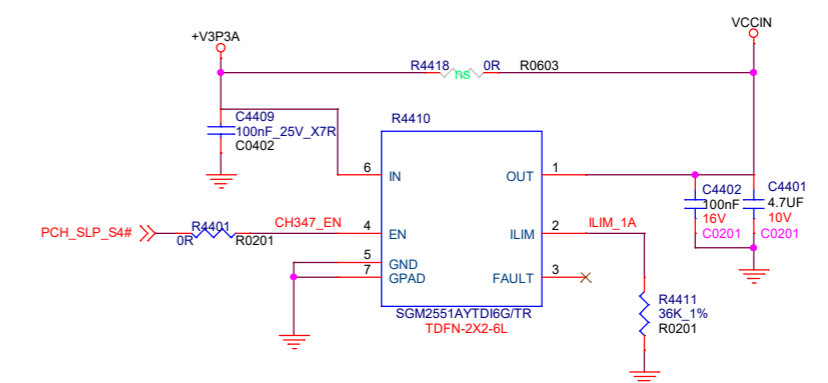

Namtso Technology Co., Ltd.			
Project:	A10-N305		
File:	Storage(USB TO SPI)		
Date:	Friday, February 02, 2024	Rev:	V12
Designed_by:	Victor Chen	Sheet:	21

UFS

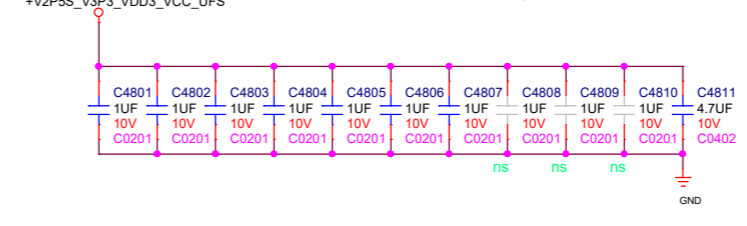
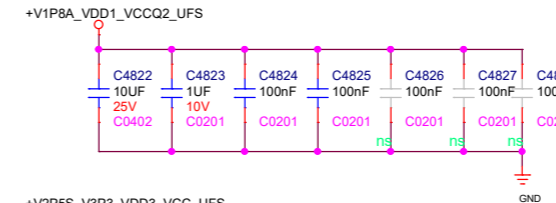
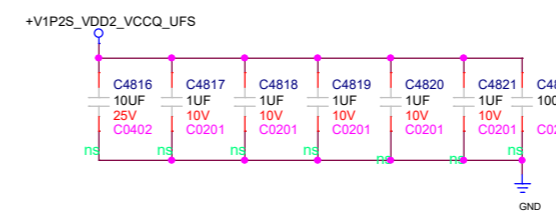
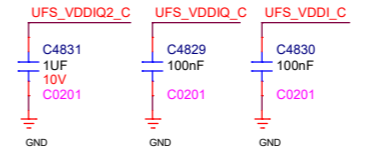
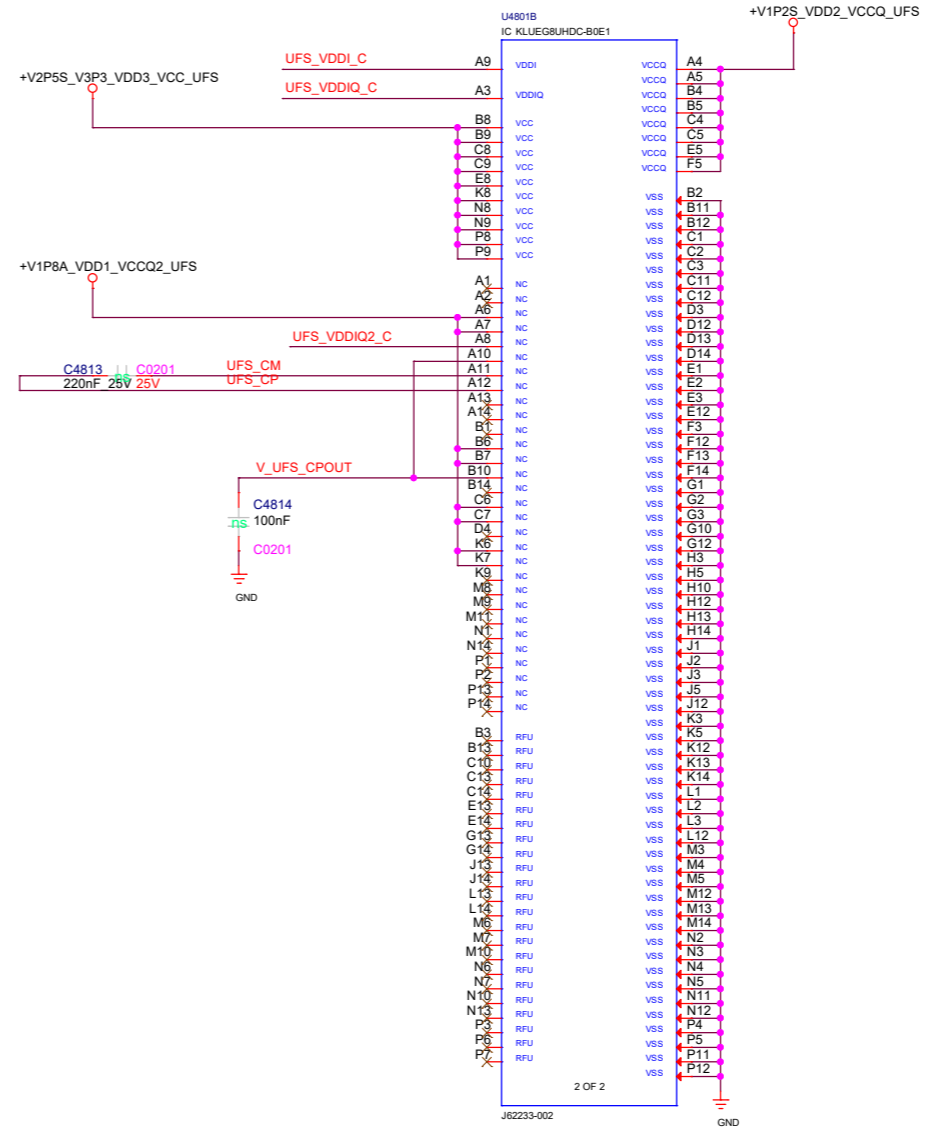
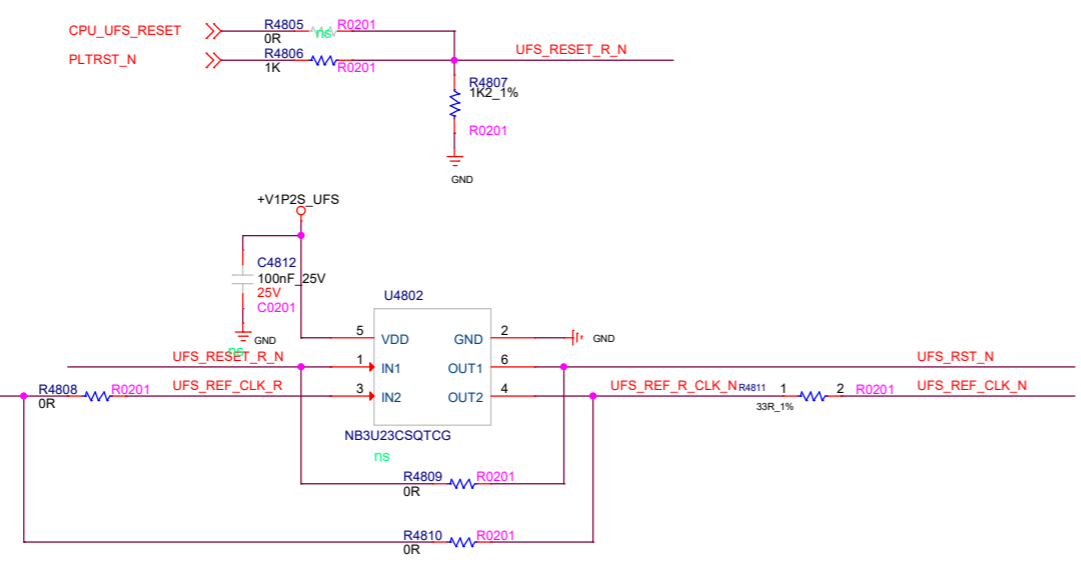
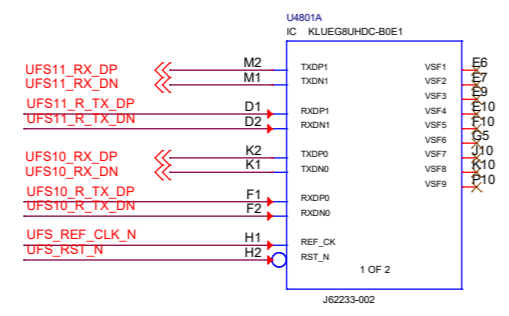
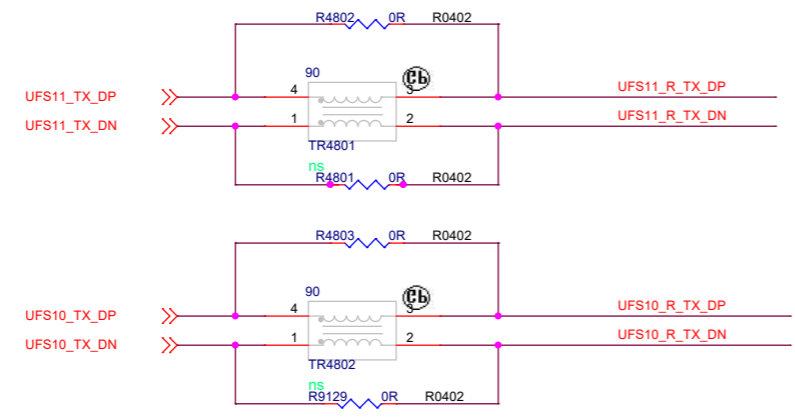
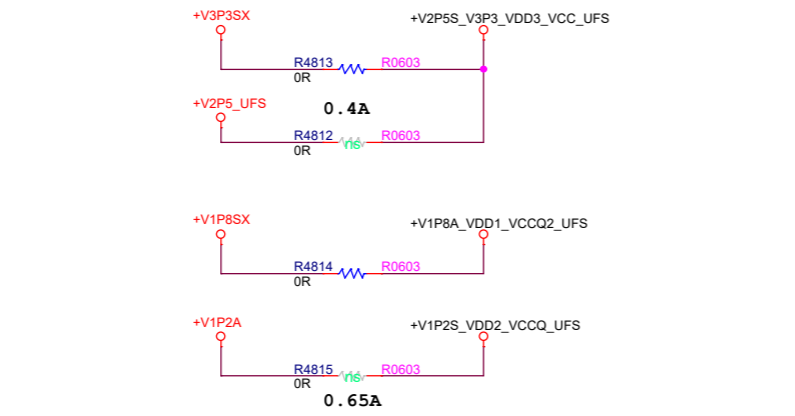

Namts Technology Co., Ltd.			
Project:	A10-N305		
File:	Storage(UFS 2.1)		
Date:	Friday, February 02, 2024	Rev:	V12
Designed_by:	Victor Chen	Sheet:	22

USB CONN

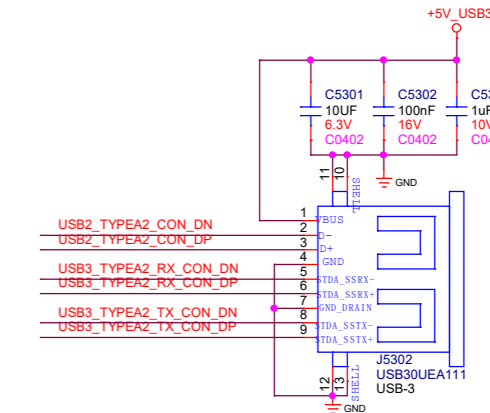
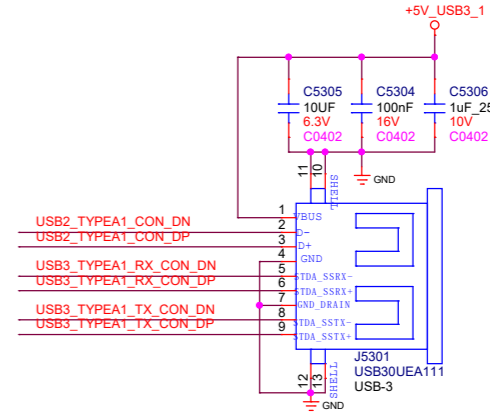
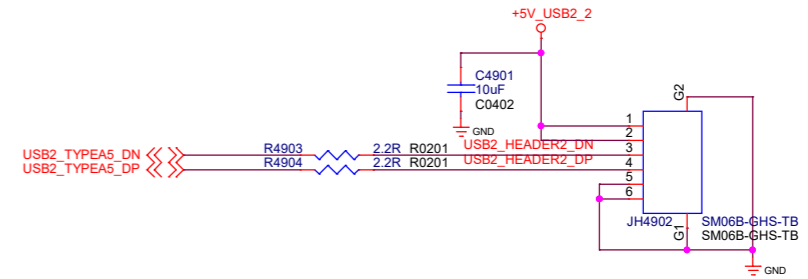
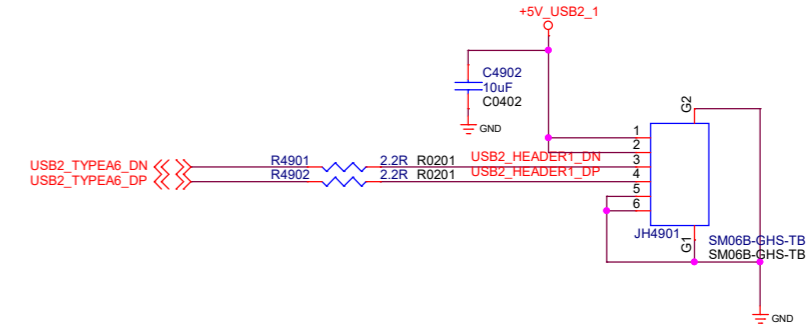
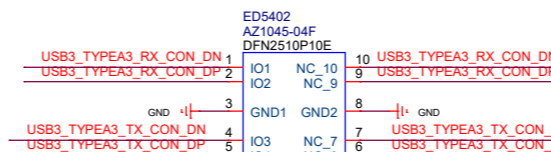
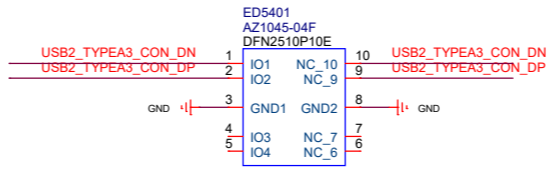
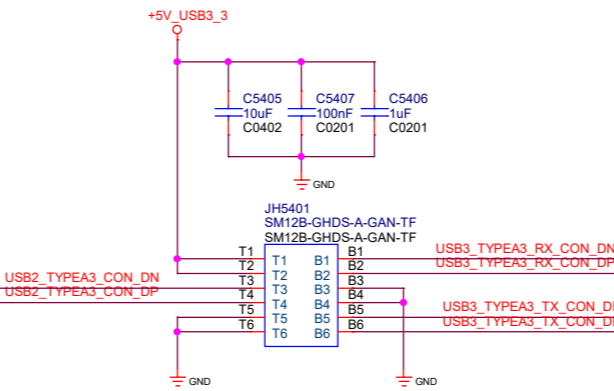
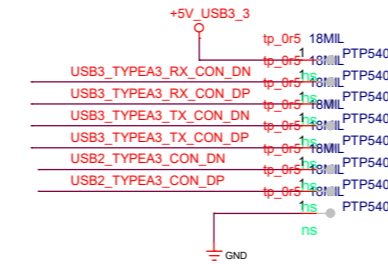
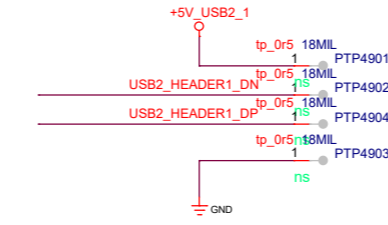
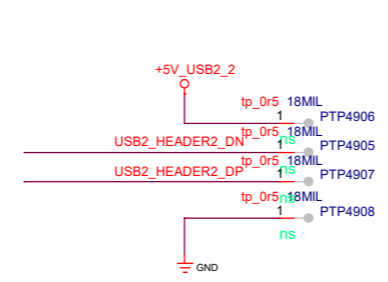
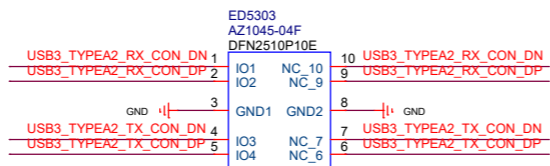
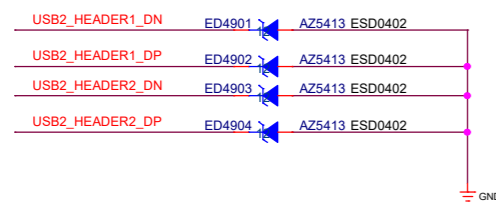
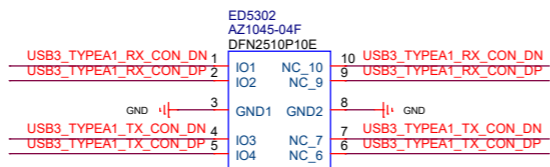
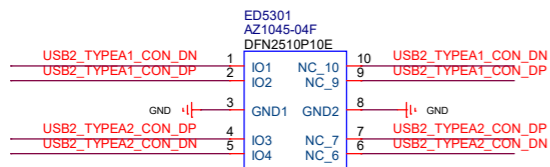
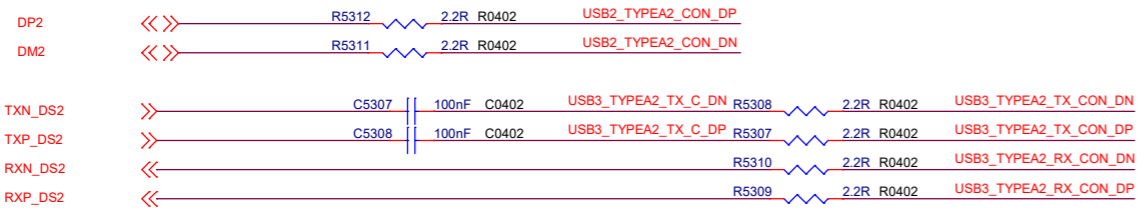
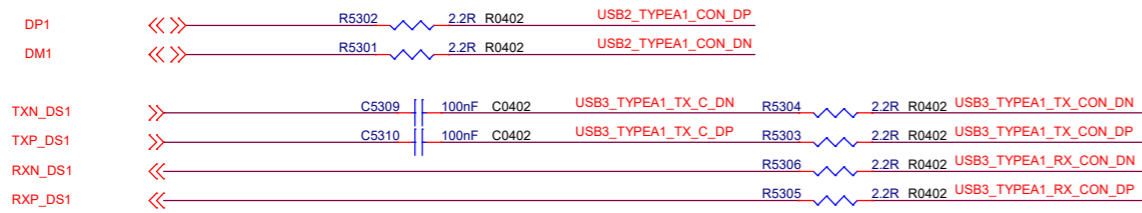
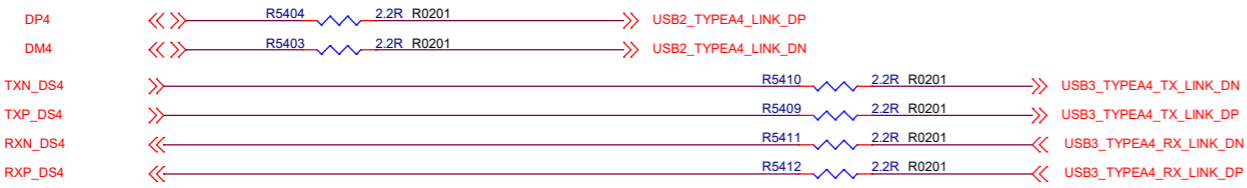
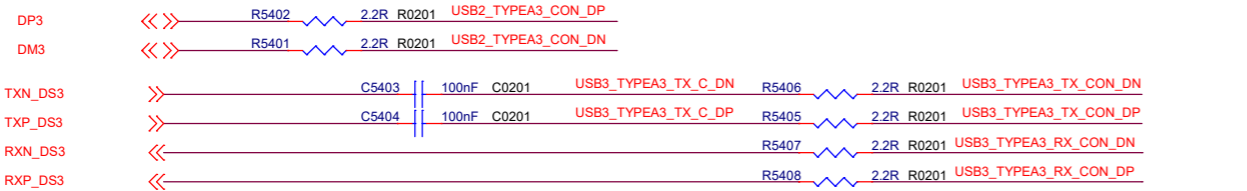

Namtso Technology Co., Ltd.			
Project:	A10-N305		
File:	Storage(USB2_CONN)		
Date:	Friday, February 02, 2024	Rev:	V12
Designed_by:	Victor Chen	Sheet:	23

USB POWER

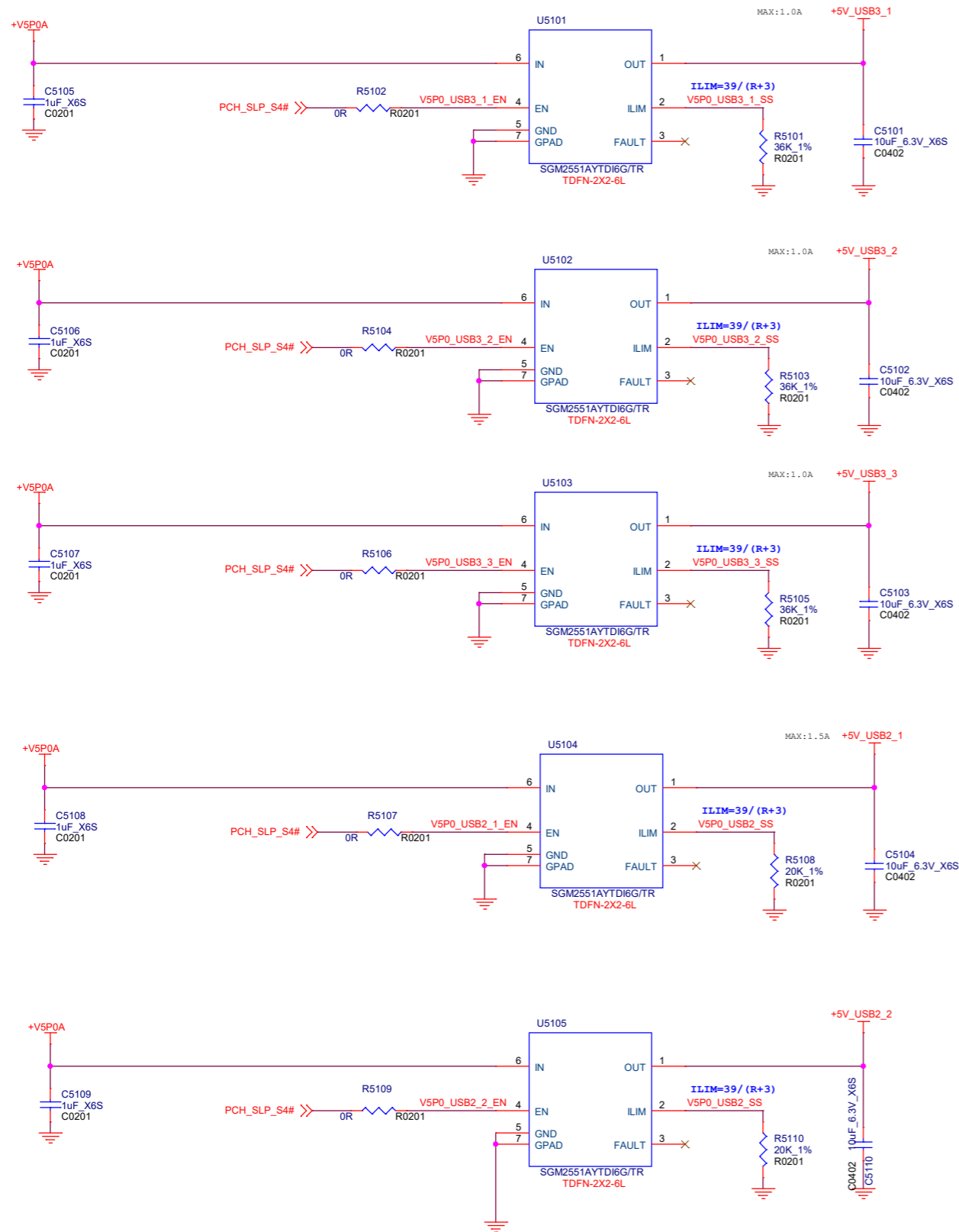

TYPE-C POWER

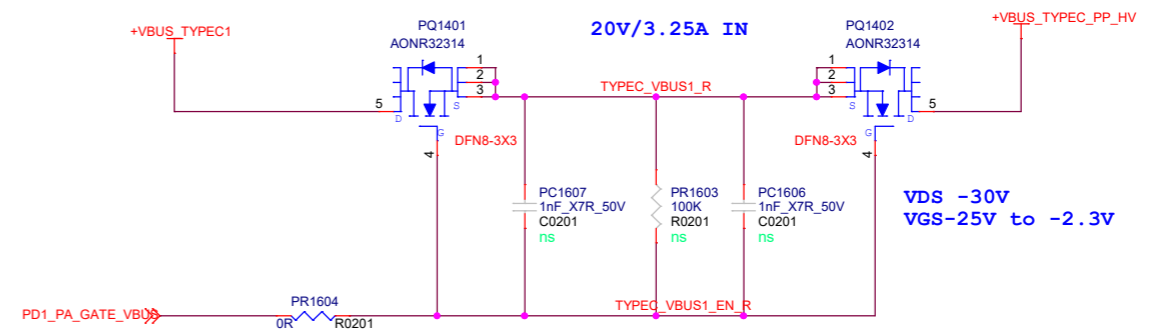

Namtso Technology Co., Ltd.			
Project:	A10-N305		
File:	USB POWER		
Date:	Friday, February 02, 2024	Rev:	V12
Designed_by:	Victor Chen	Sheet:	24

USB_HUB

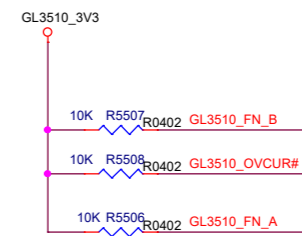
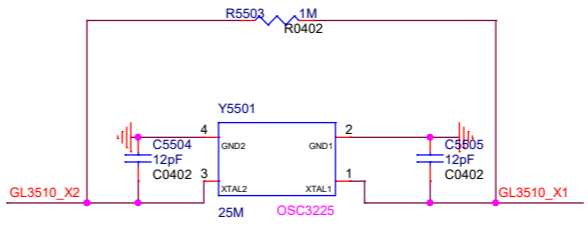
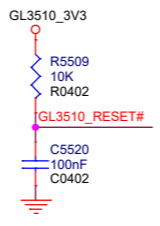
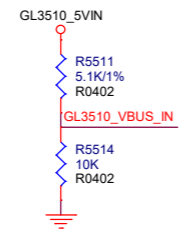
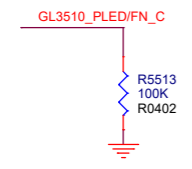
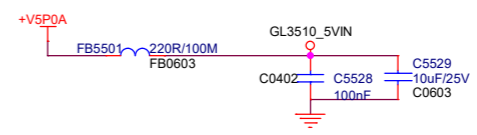
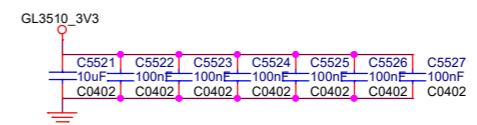
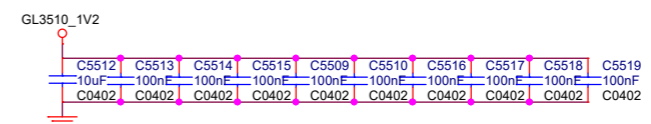
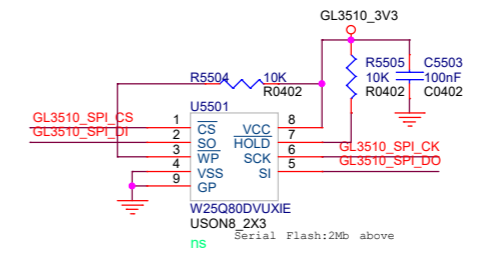
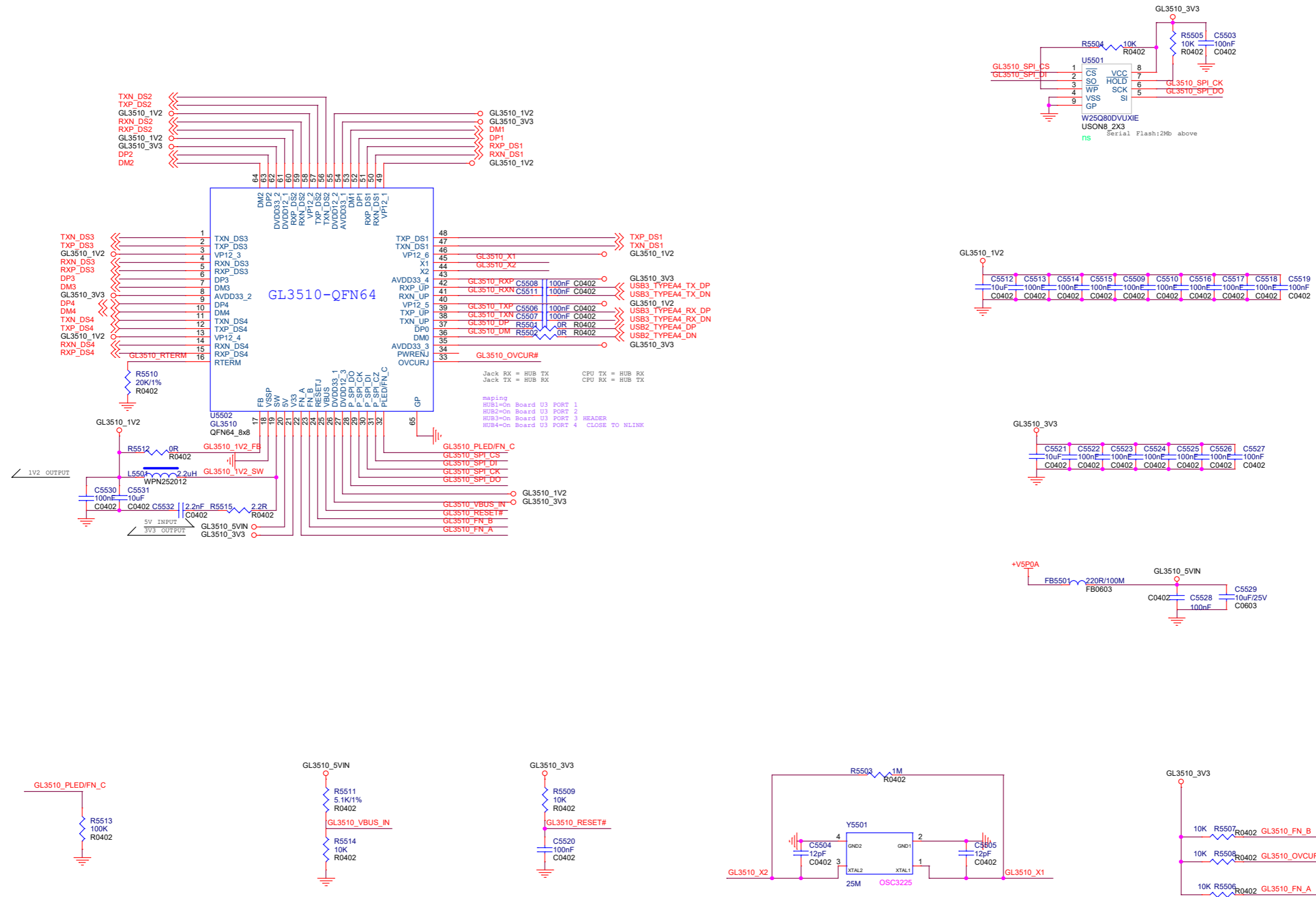

Namtso Technology Co., Ltd.			
Project:	A10-N305		
File:	USB_HUB		
Date:	Friday, February 02, 2024	Rev:	V12
Designed_by:	Victor Chen	Sheet:	25

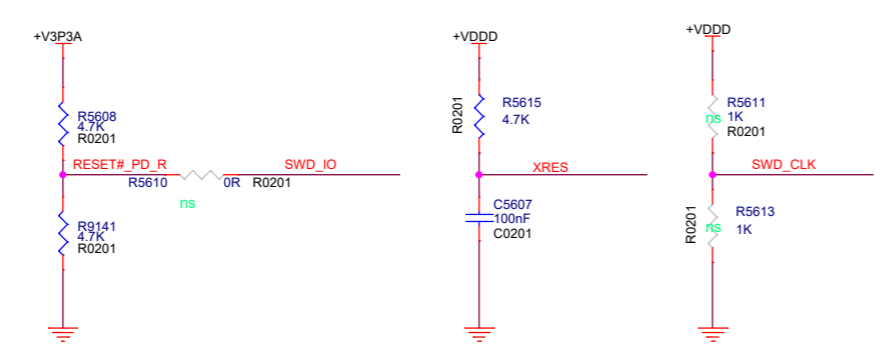
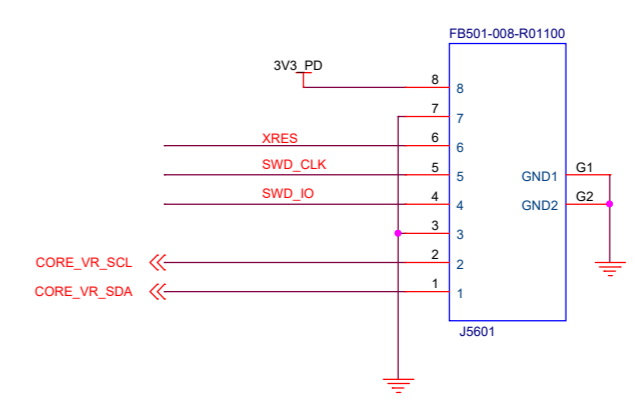
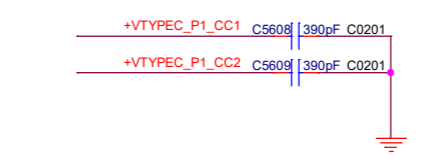
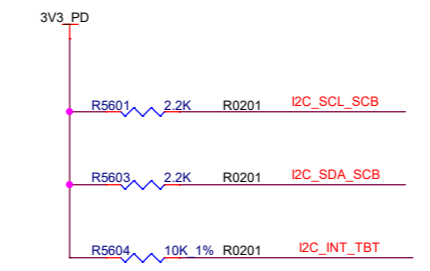
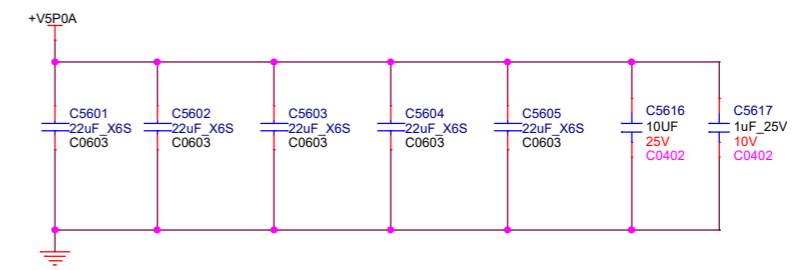
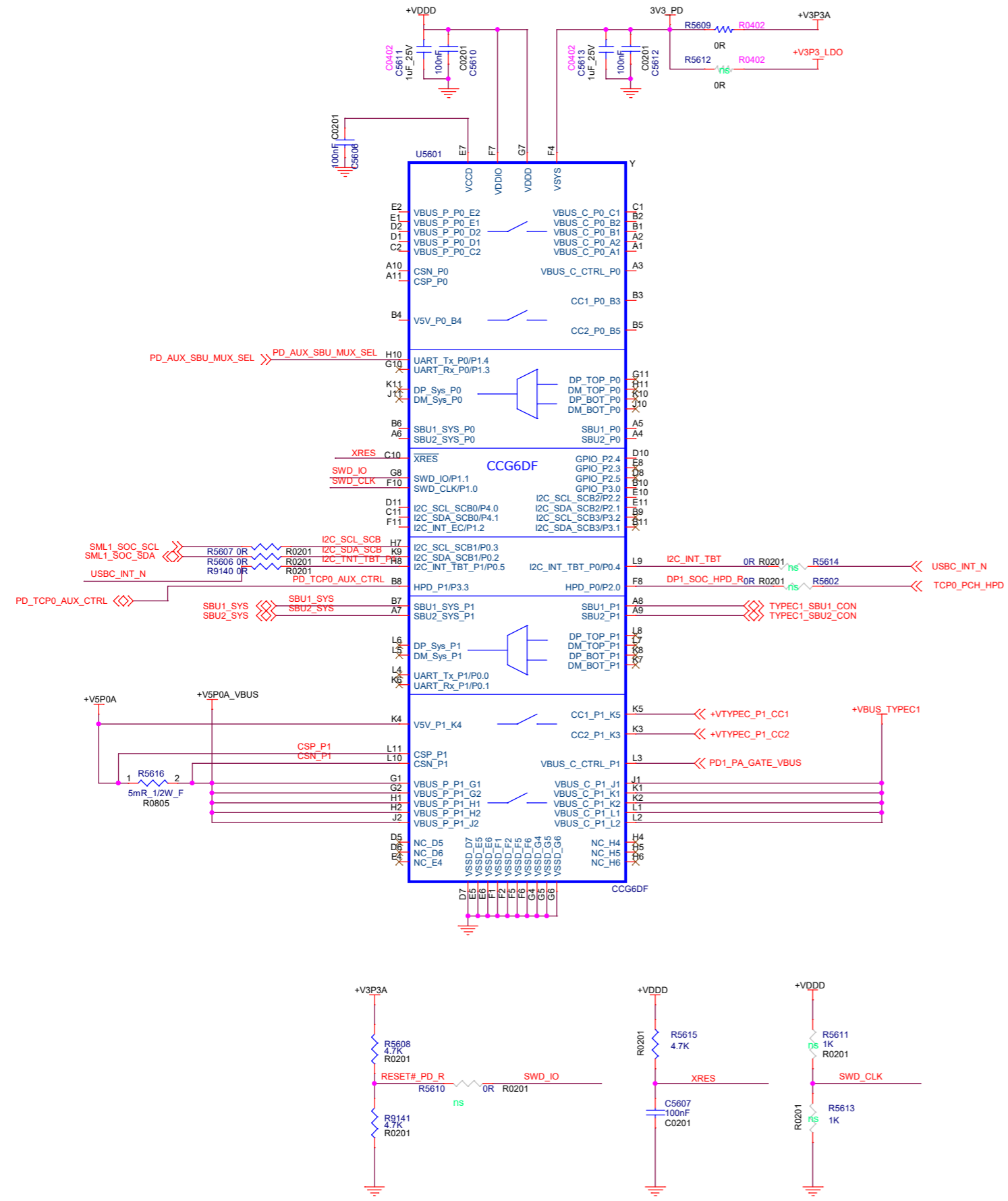

Namtso Technology Co., Ltd.			
Project:	A10-N305		
File:	Storage(PD)		
Date:	Friday, February 02, 2024	Rev:	V12
Designed_by:	Victor.Chen	Sheet:	26

TYPE-C CONN

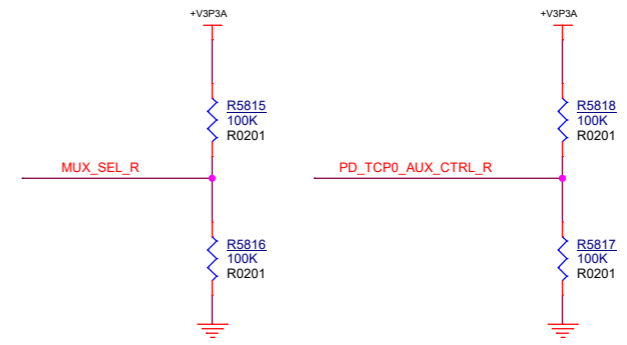
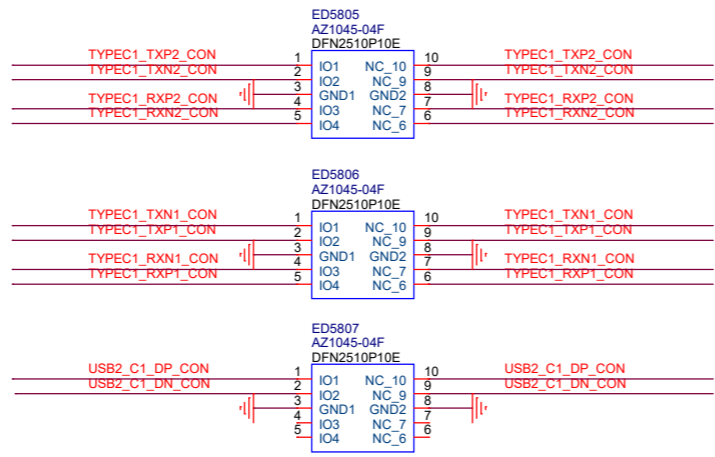
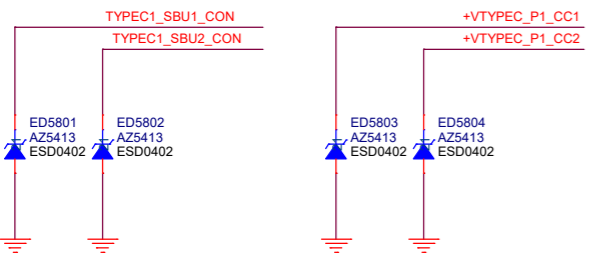
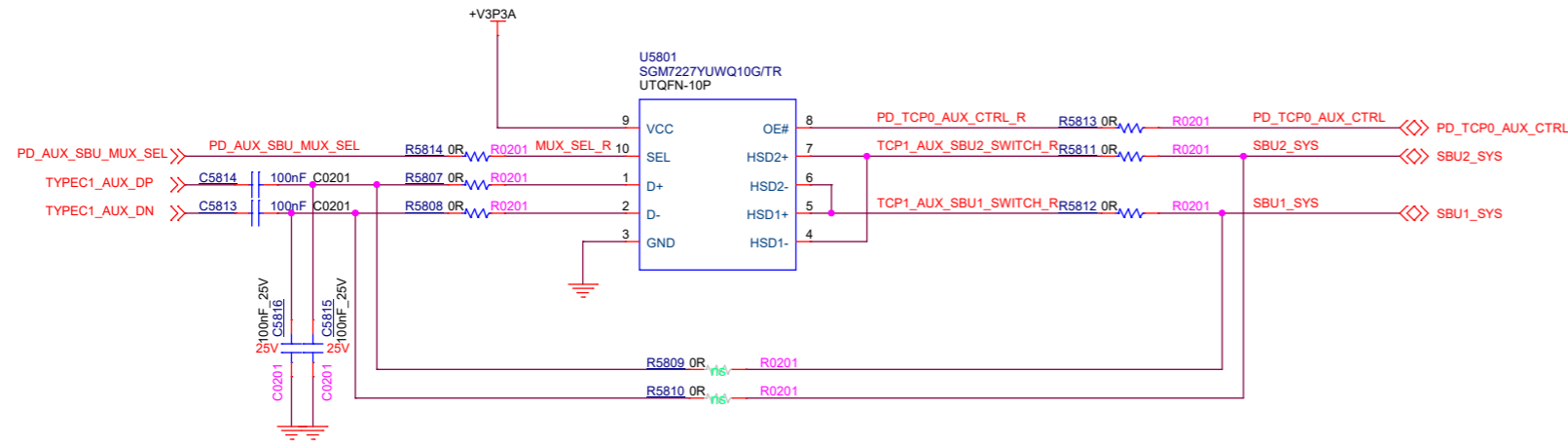
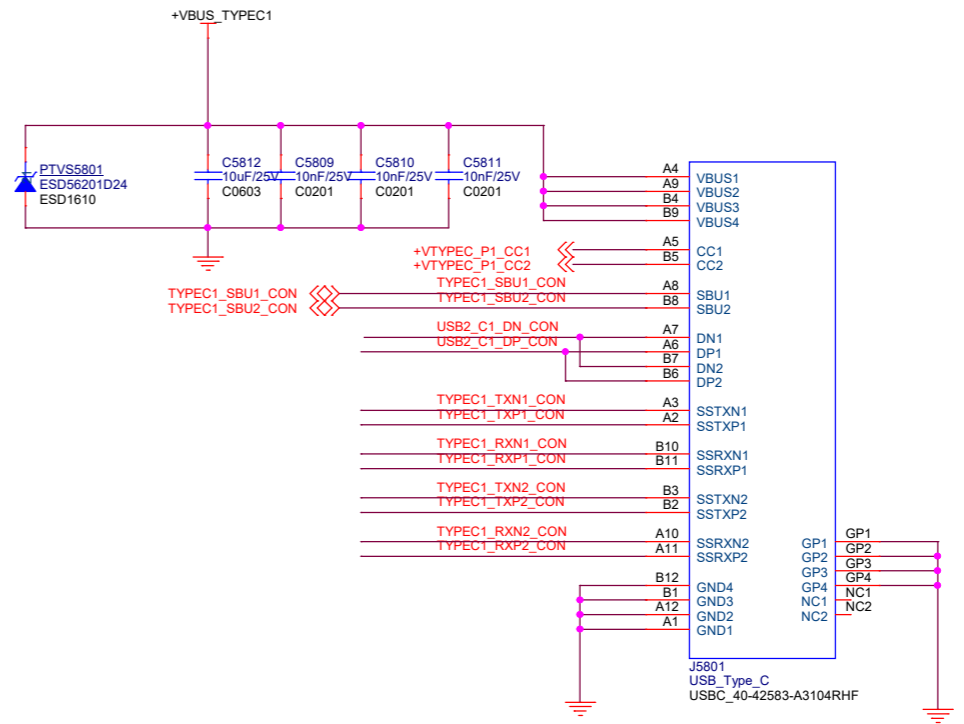
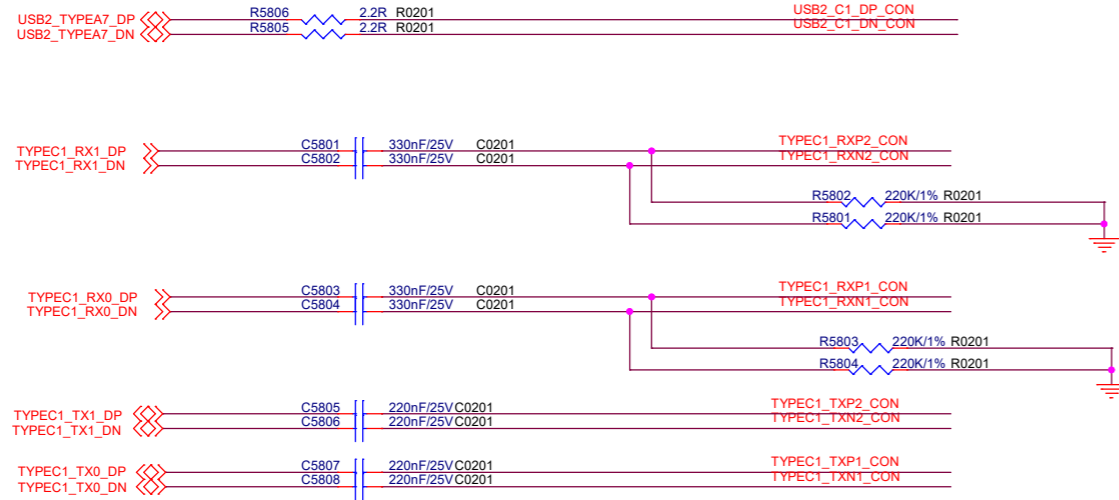

Namtso Technology Co., Ltd.			
Project:	A10-N305		
File:	Storage(YTPE C CONN)		
Date:	Friday, February 02, 2024	Rev:	V12
Designed_by:	Victor Chen	Sheet:	27

NAMTSO Link

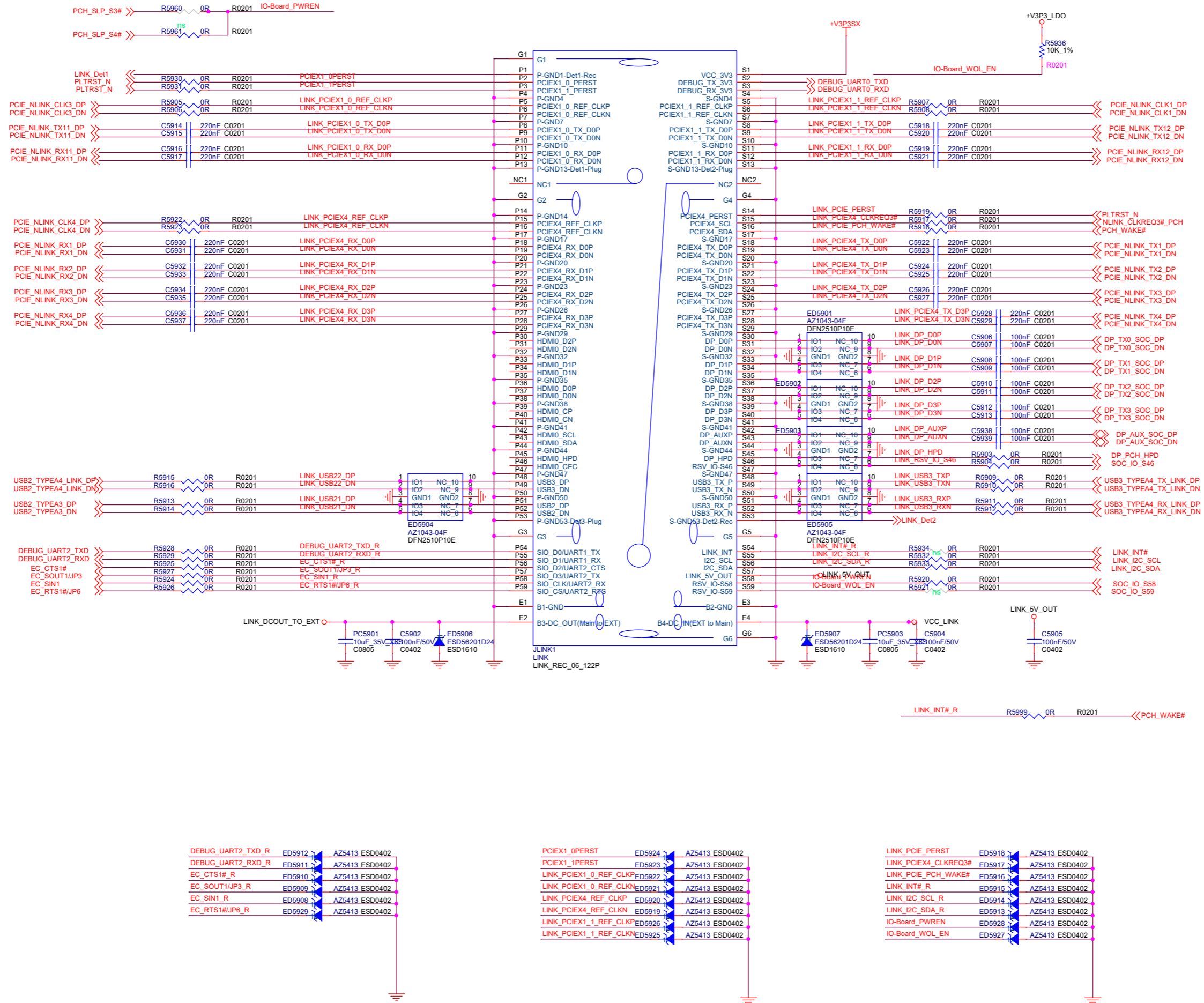

DEBUG_UART2_TXD_R	ED5912	AZ5413 ESD0402
DEBUG_UART2_RXD_R	ED5911	AZ5413 ESD0402
EC_CTS1#_R	ED5910	AZ5413 ESD0402
EC_SOUT1#JP3_R	ED5909	AZ5413 ESD0402
EC_SIN1_R	ED5908	AZ5413 ESD0402
EC_RTS1#JP6_R	ED5929	AZ5413 ESD0402

PCIEX1_0PERST	ED5924	AZ5413 ESD0402
PCIEX1_1PERST	ED5923	AZ5413 ESD0402
LINK_PCIEX1_0_REF_CLKP	ED5922	AZ5413 ESD0402
LINK_PCIEX1_0_REF_CLKN	ED5921	AZ5413 ESD0402
LINK_PCIEX4_REF_CLKP	ED5920	AZ5413 ESD0402
LINK_PCIEX4_REF_CLKN	ED5919	AZ5413 ESD0402
LINK_PCIEX1_1_REF_CLKP	ED5926	AZ5413 ESD0402
LINK_PCIEX1_1_REF_CLKN	ED5925	AZ5413 ESD0402

LINK_PCIE_PERST	ED5918	AZ5413 ESD0402
LINK_PCIEX4_CLKREQ3#	ED5917	AZ5413 ESD0402
LINK_PCIE_PCH_WAKE#	ED5916	AZ5413 ESD0402
LINK_INT#_R	ED5915	AZ5413 ESD0402
LINK_I2C_SCL_R	ED5914	AZ5413 ESD0402
LINK_I2C_SDA_R	ED5913	AZ5413 ESD0402
IO-Board_PWREN	ED5928	AZ5413 ESD0402
IO-Board_WOL_EN	ED5927	AZ5413 ESD0402

Namtso Technology Co., Ltd.			
Project:	A10-N305		
File:	SLOT(LINK)		
Date:	Sunday, February 04, 2024	Rev:	V12
Designed_by:	Victor.Chen	Sheet:	28

CNVI WLAN

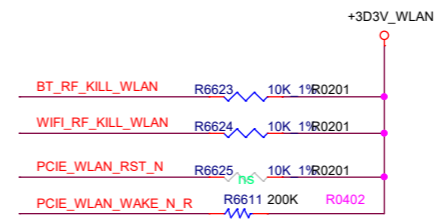
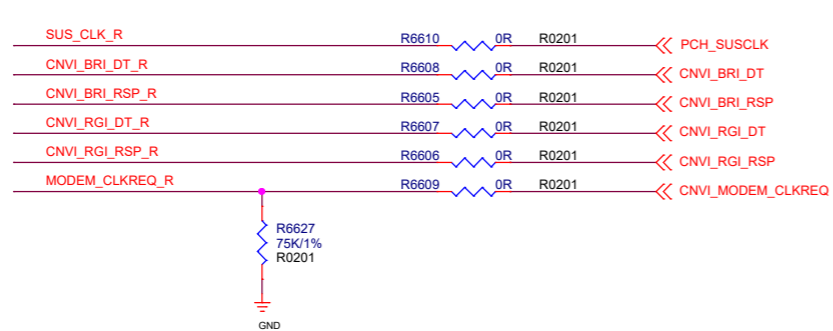
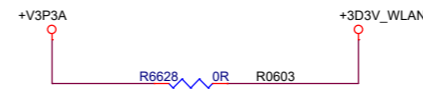
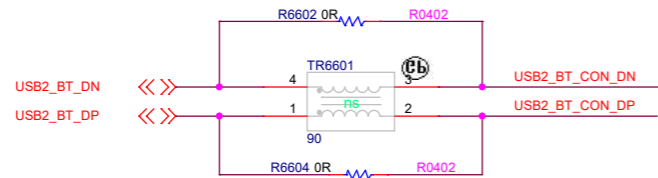
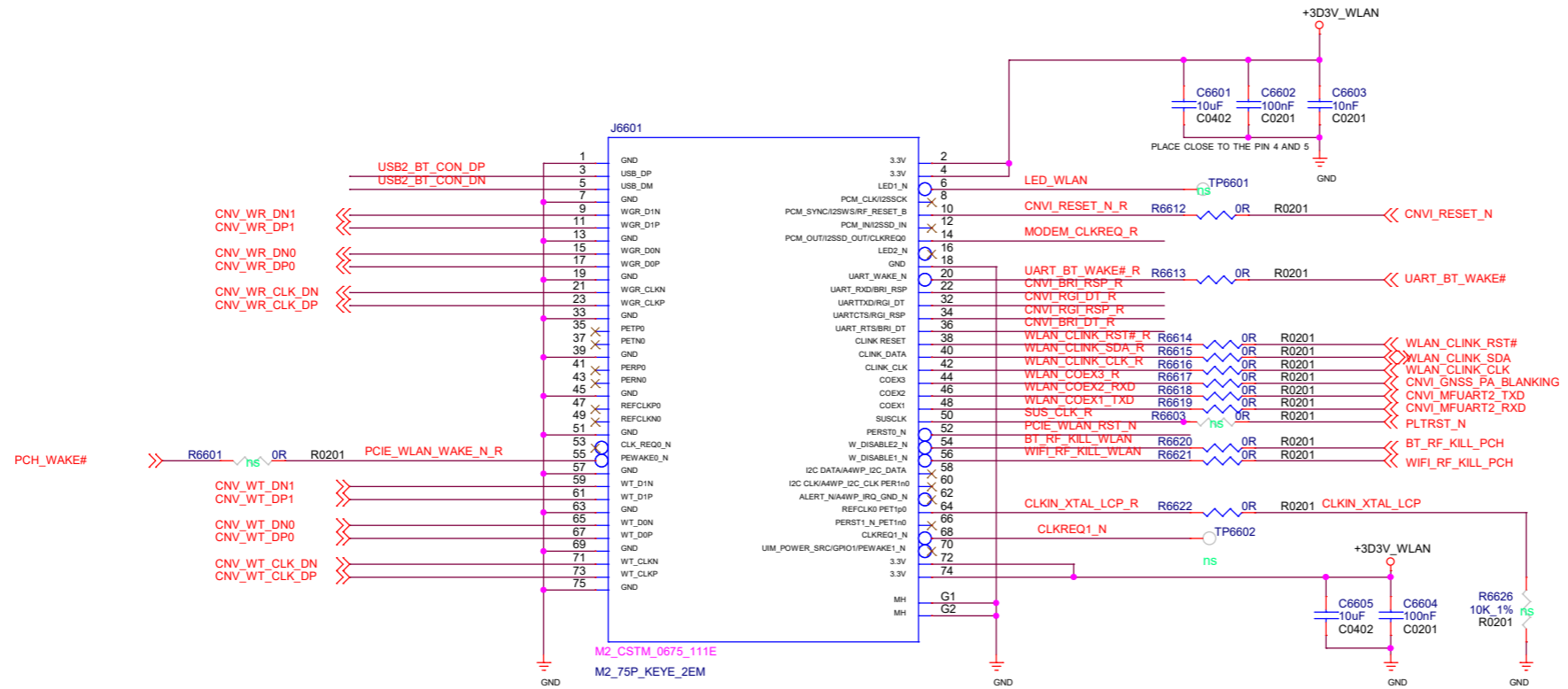

Namtso Technology Co., Ltd.			
Project:	A10-N305		
File:	Conection(WLAN_CNVI)		
Date:	Friday, February 02, 2024	Rev:	V12
Designed_by:	Victor Chen	Sheet:	29

LAN Controller

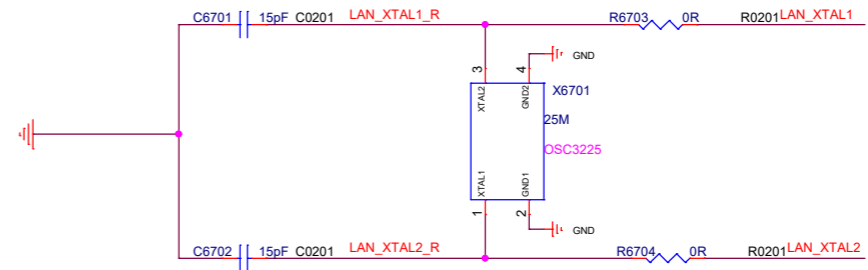
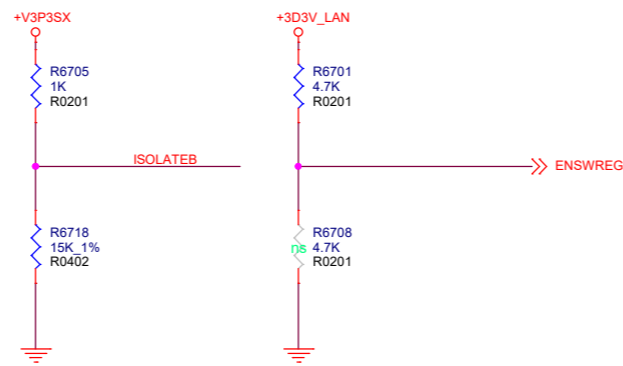
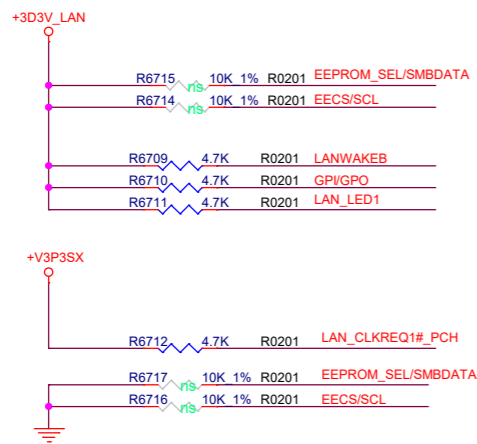
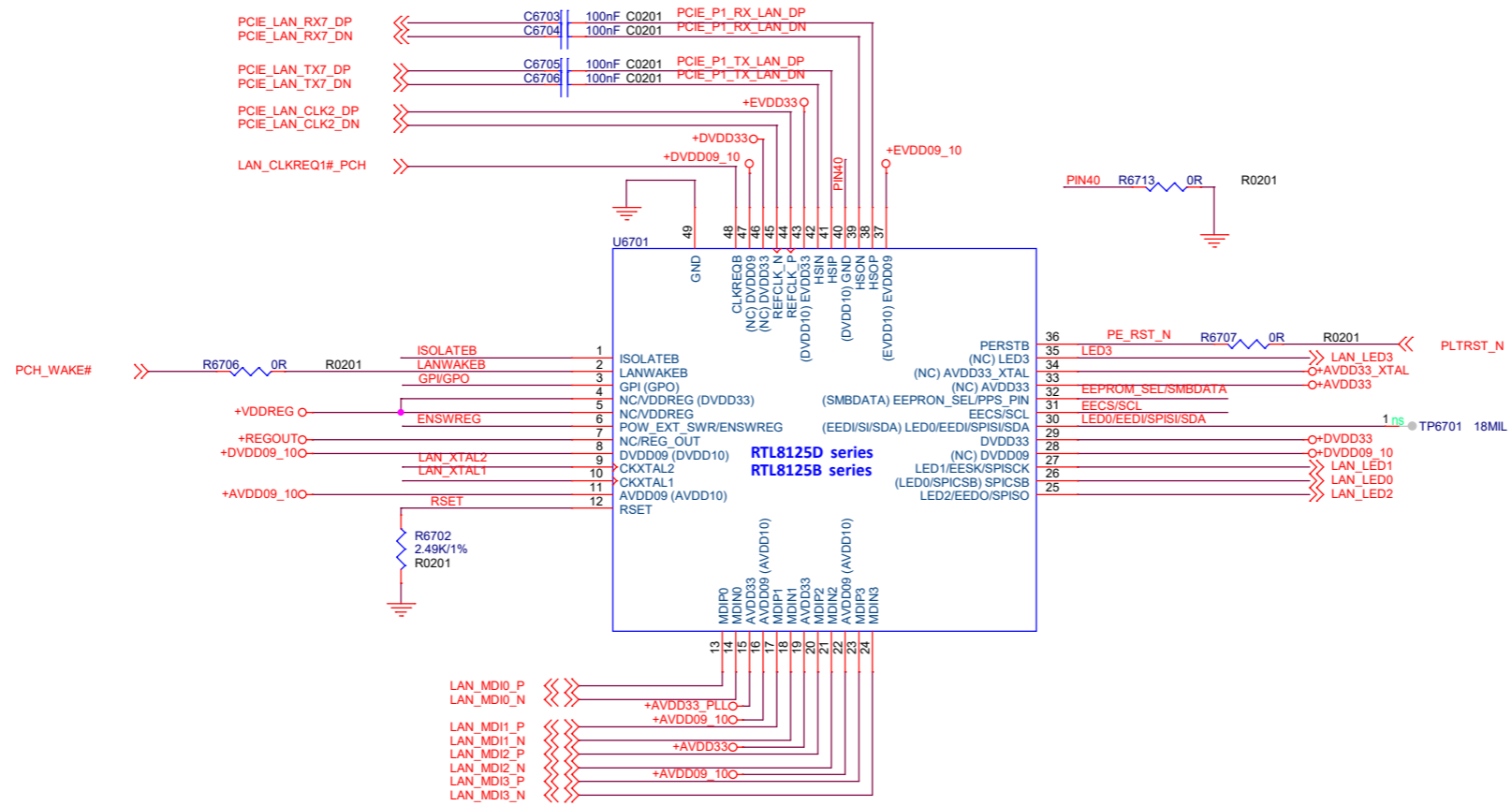

Namtso Technology Co., Ltd.			
Project:	A10-N305		
File:	Conection(LAN Controller)		
Date:	Friday, February 02, 2024	Rev:	V12
Designed_by:	Victor Chen	Sheet:	30

LAN POWER

5

4

3

2

1

S0	S3	S5	DS
H	H	H	L

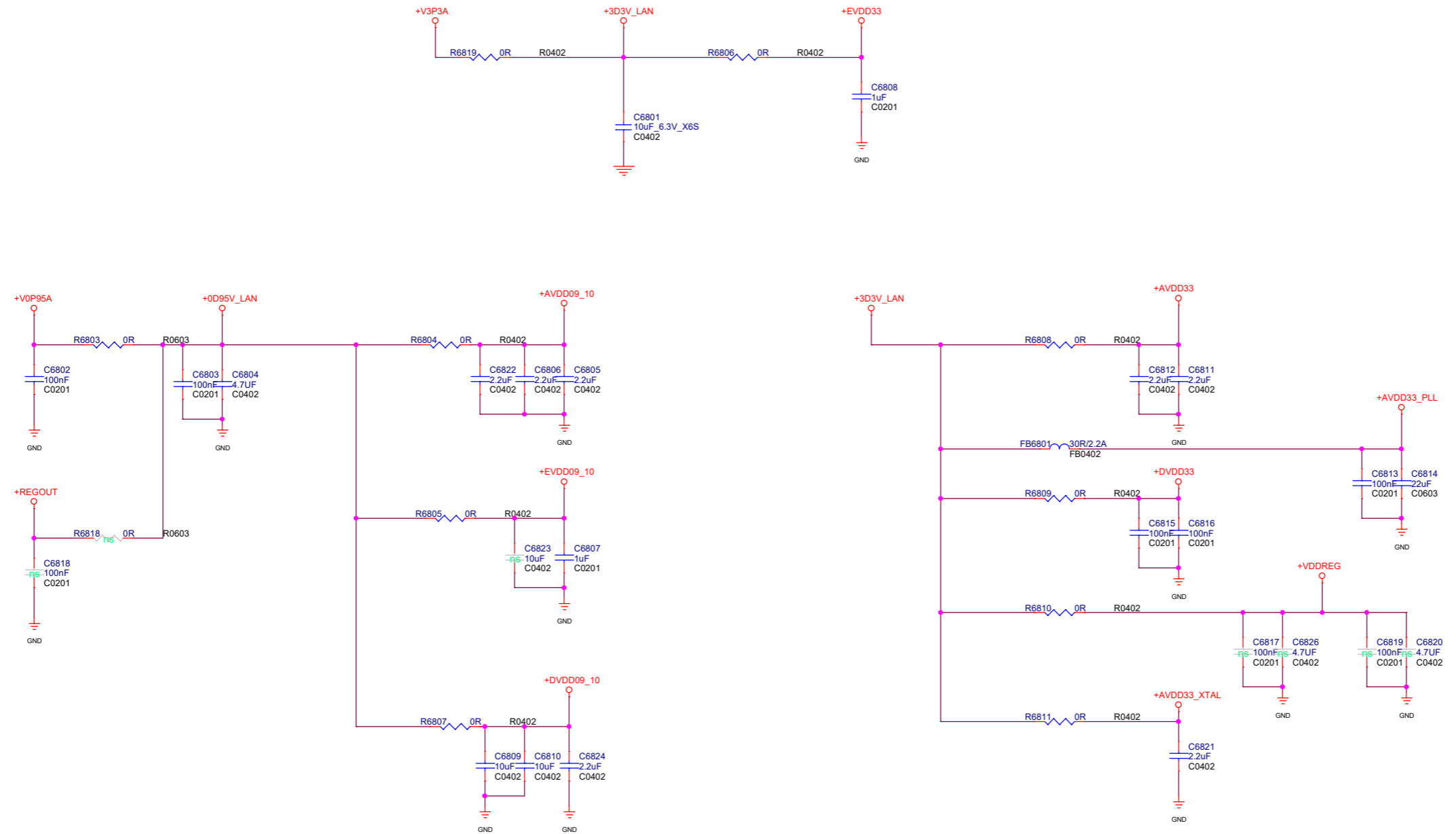

Namtso Technology Co., Ltd.			
Project:	A10-N305		
File:	Conection(LAN Power)		
Date:	Friday, February 02, 2024	Rev:	V12
Designed_by:	Victor Chen	Sheet:	31

5

4

3

2

1

2.5G Lan Transformer

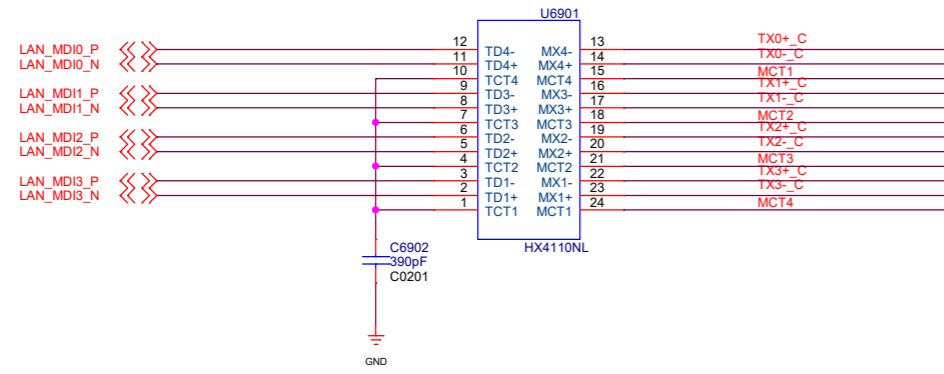

LAN Connector

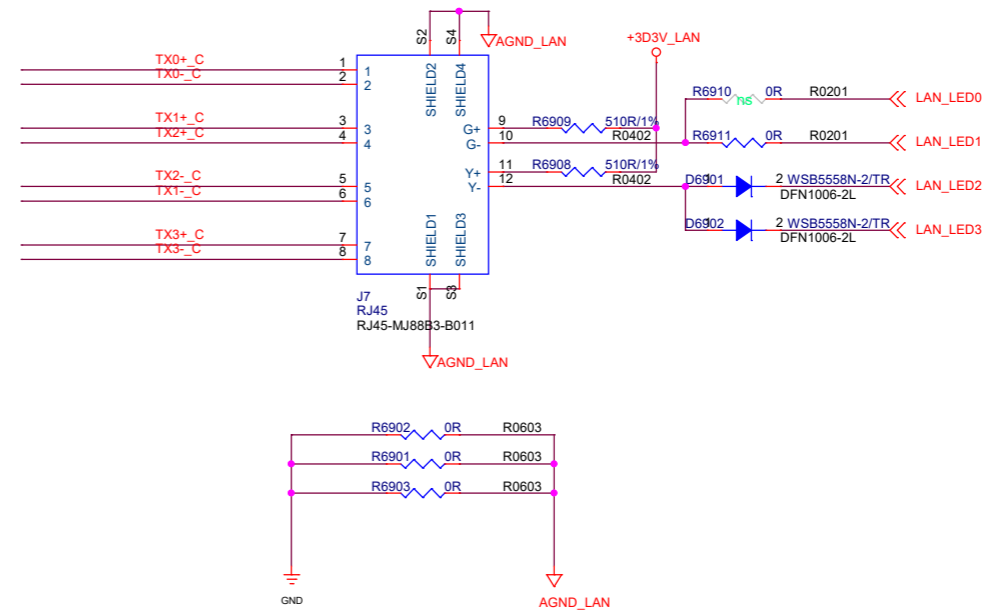

Lan Surge

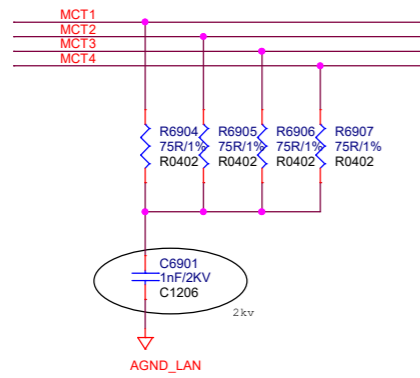

ESD

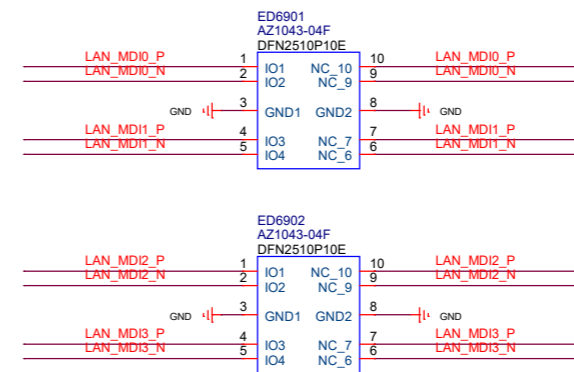

Namtso Technology Co., Ltd.			
Project:	A10-N305		
File:	Conection(LAN CONN)		
Date:	Friday, February 02, 2024	Rev:	V12
Designed_by:	Victor Chen	Sheet:	32

Power BTN

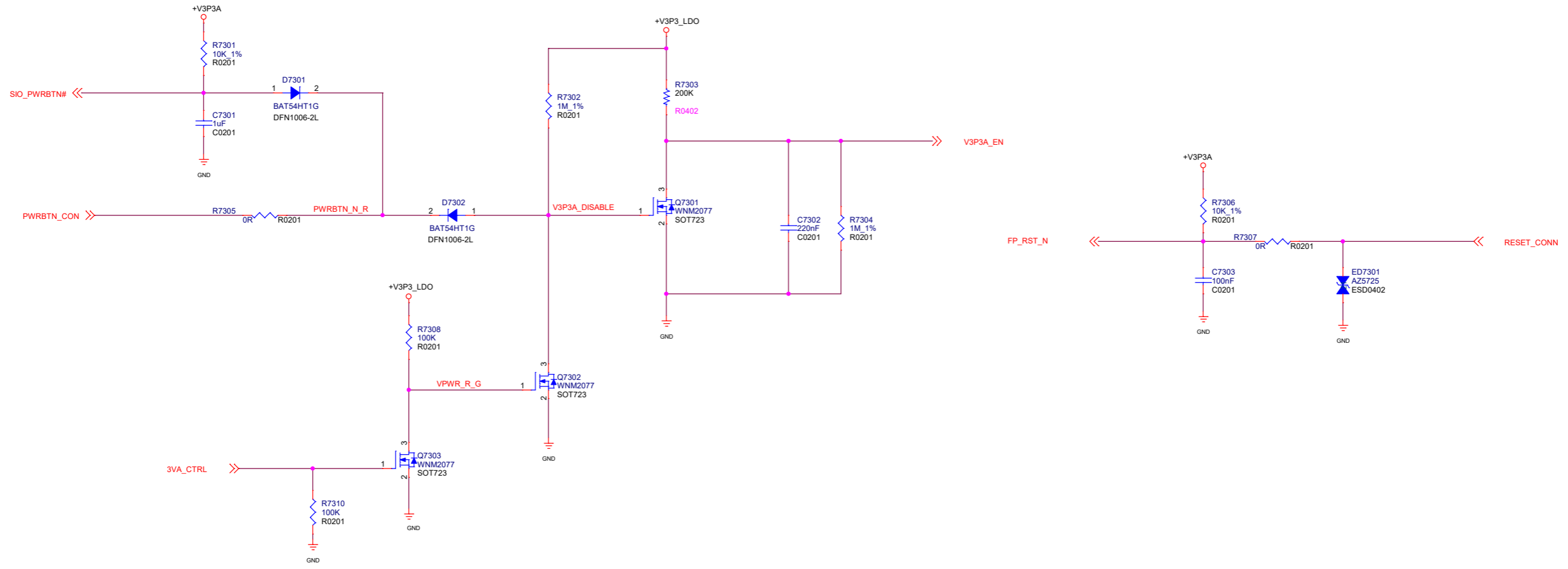

GPIO Header

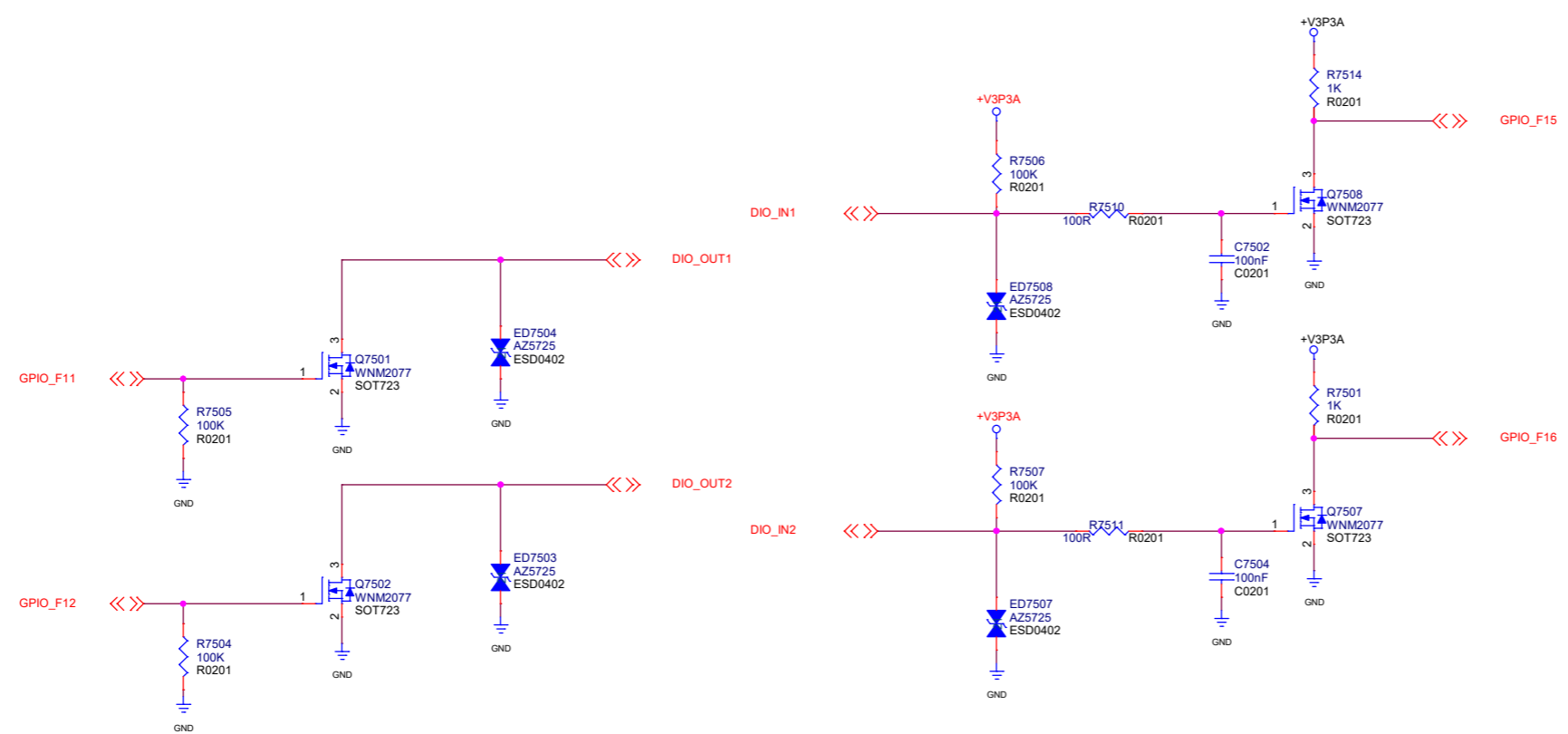

Namtso Technology Co., Ltd.			
Project:	A10-N305		
File:	Conection(Power BTN)		
Date:	Friday, February 02, 2024	Rev:	V12
Designed_by:	Victor Chen	Sheet:	33

SYS LED CONTROL

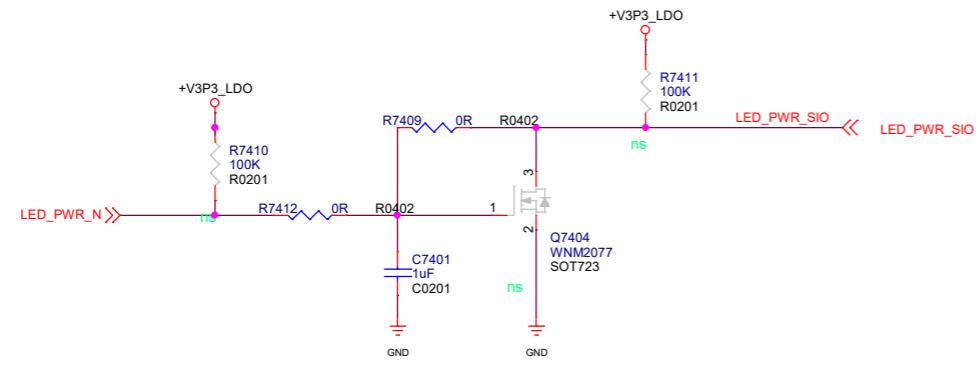

HDD LED

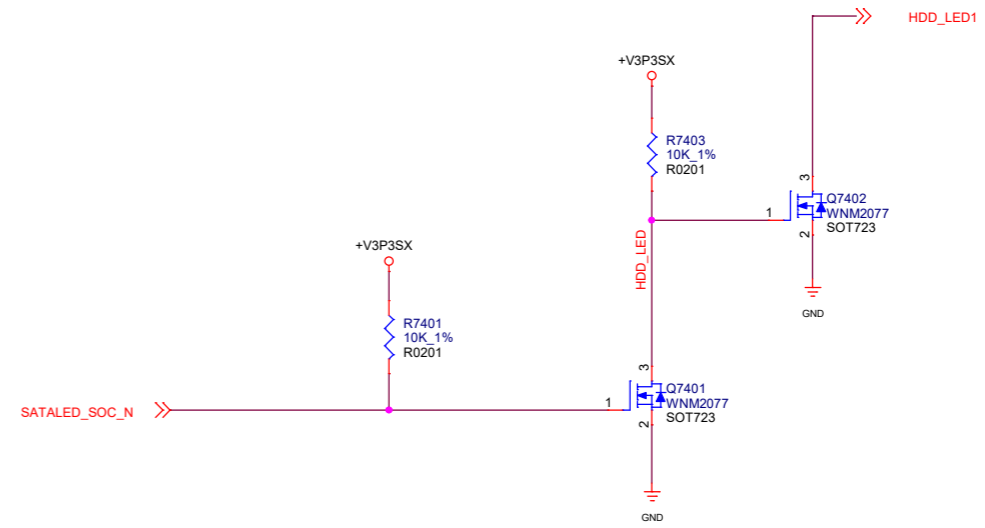

RED LED

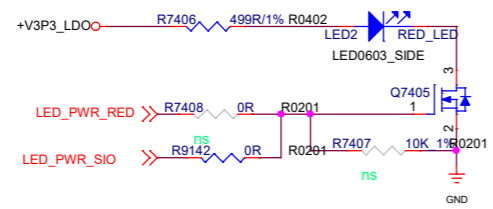

POWER LED

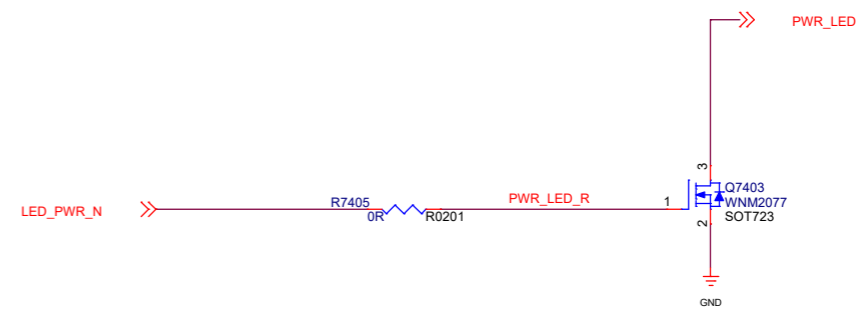

Namtso Technology Co., Ltd.			
Project:	A10-N305		
File:	Conection(PANEL/CHAS/LED)		
Date:	Friday, February 02, 2024	Rev:	V12
Designed_by:	Victor Chen	Sheet:	34

CODEC

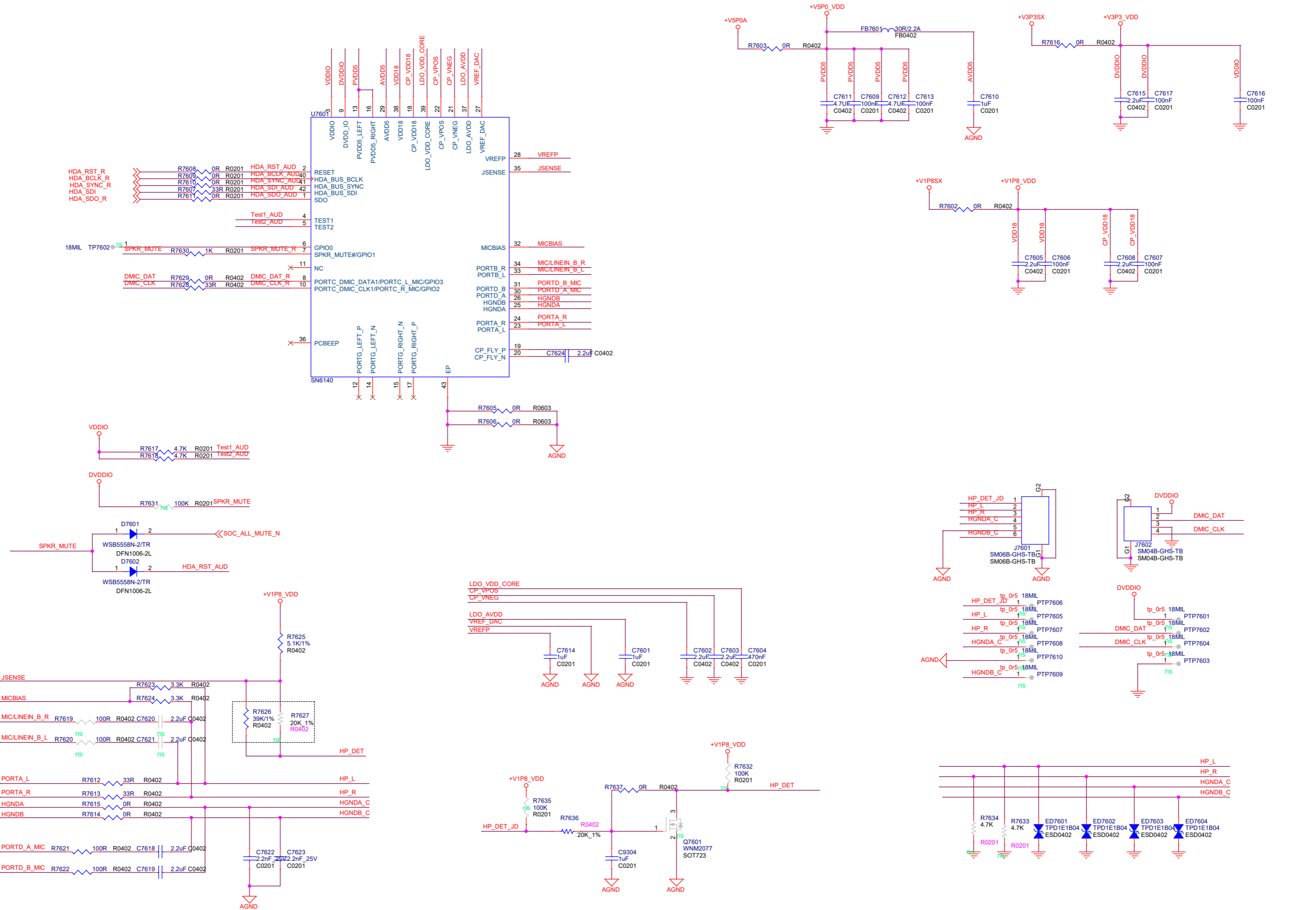

Namtso Technology Co., Ltd.			
Project:	A10-N305		
File:	AUDIO(SN6140)		
Date:	Friday, February 02, 2024	Rev:	V12
Designed_by:	Victor Chen	Sheet:	35

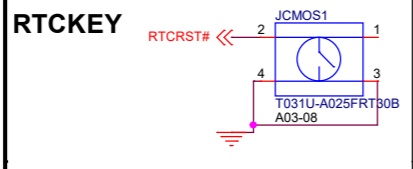
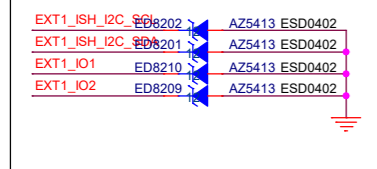
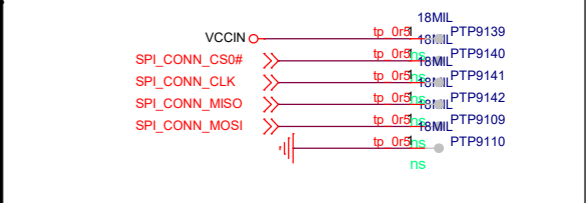
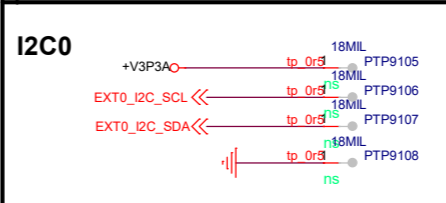
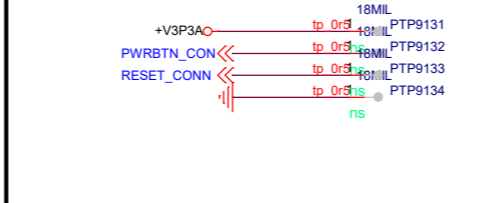
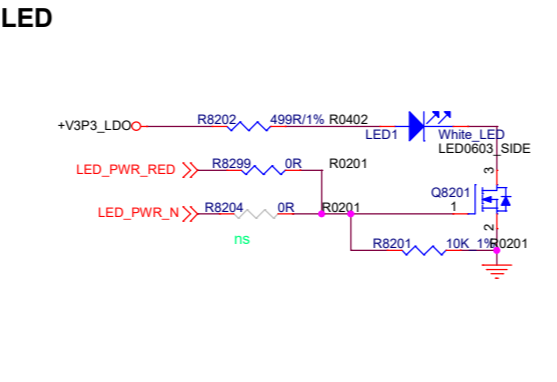
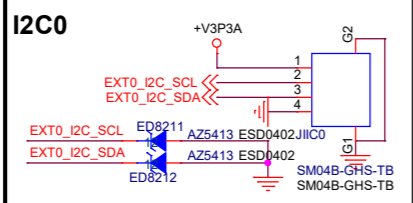
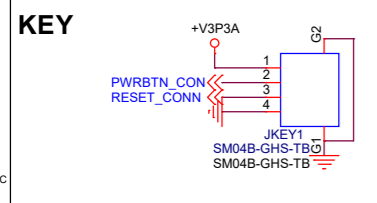
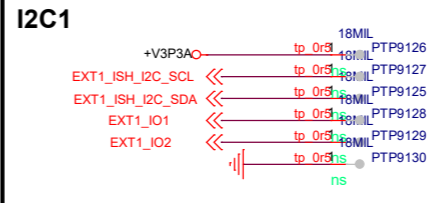
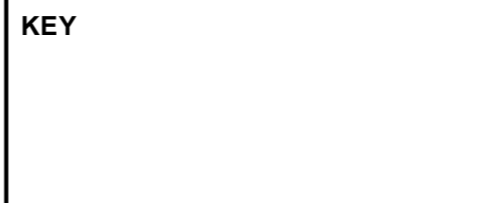
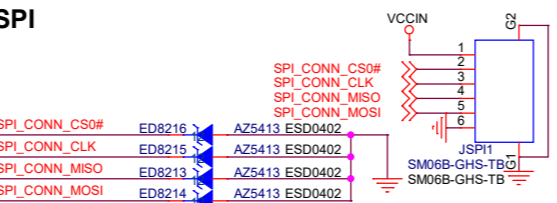
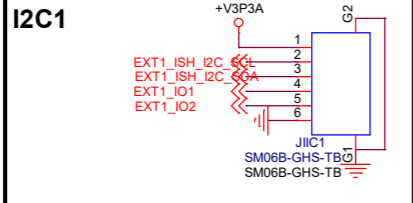
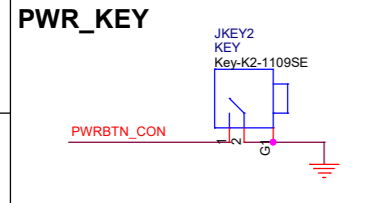
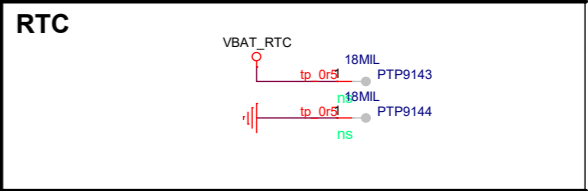
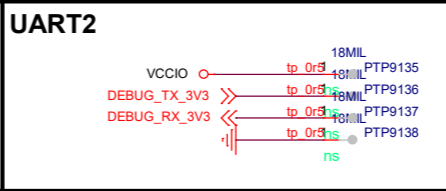
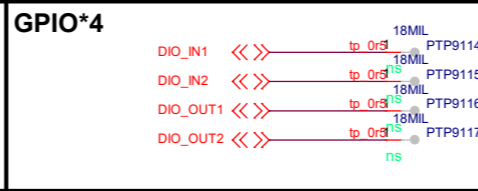
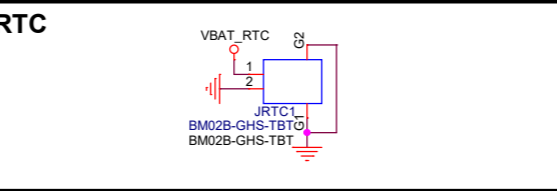
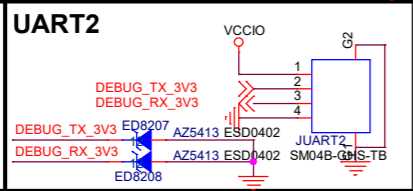
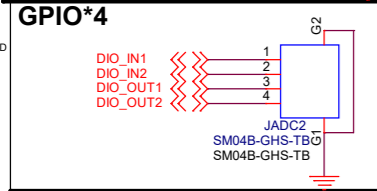
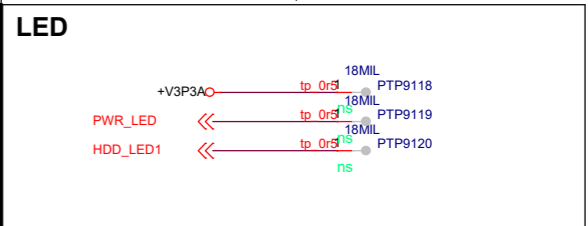
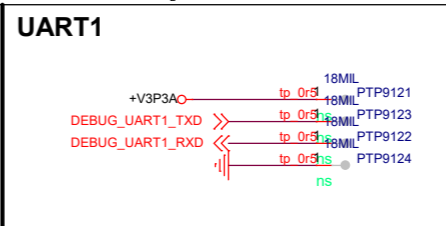
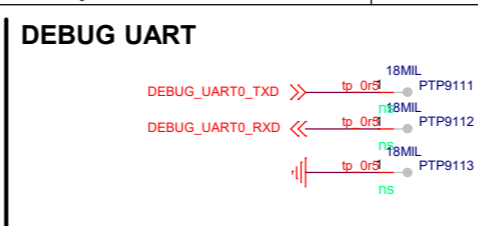
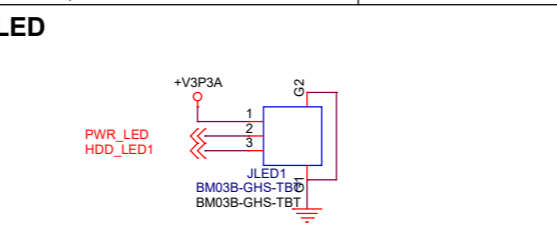
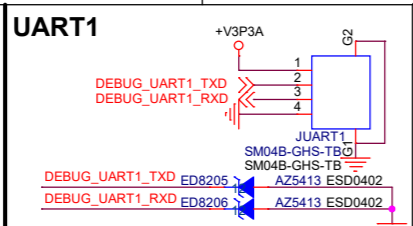
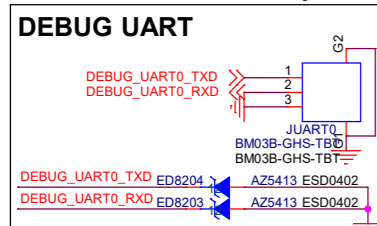

Gsensor

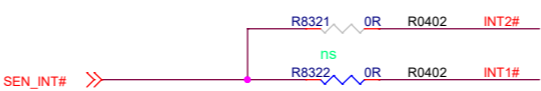
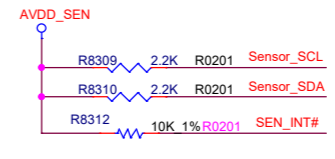
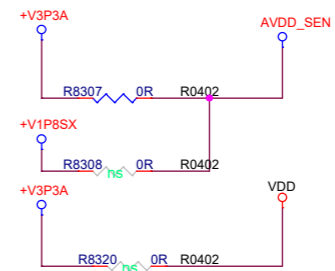
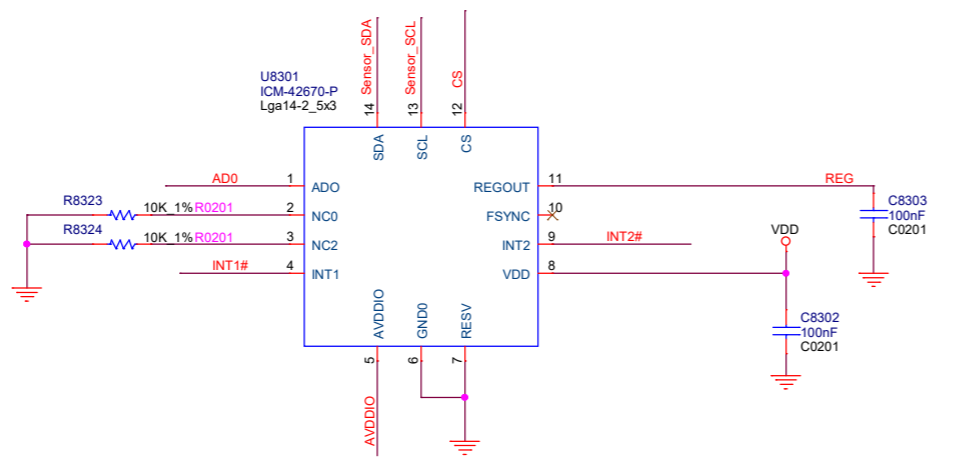

Namts Technology Co., Ltd.			
Project:	A10-N305		
File:	FUNC(Reserved)		
Date:	Monday, February 05, 2024	Rev:	V12
Designed_by:	Victor Chen	Sheet:	36

HOLE

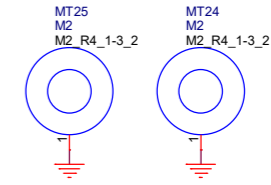
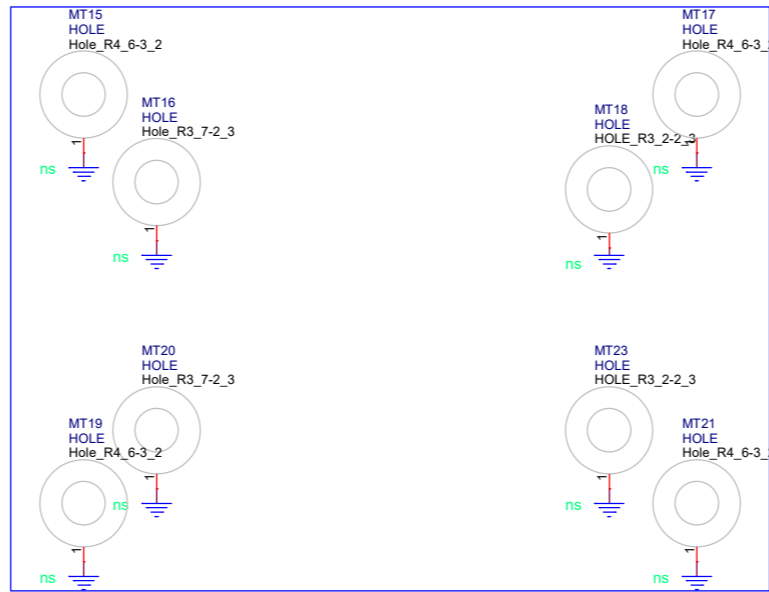
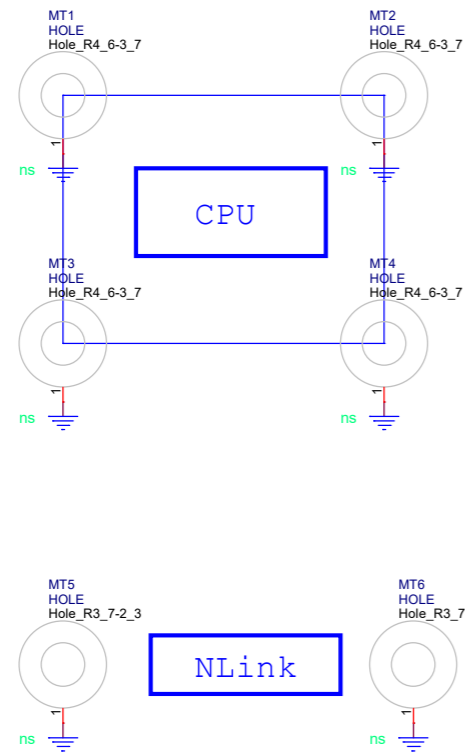

FAN

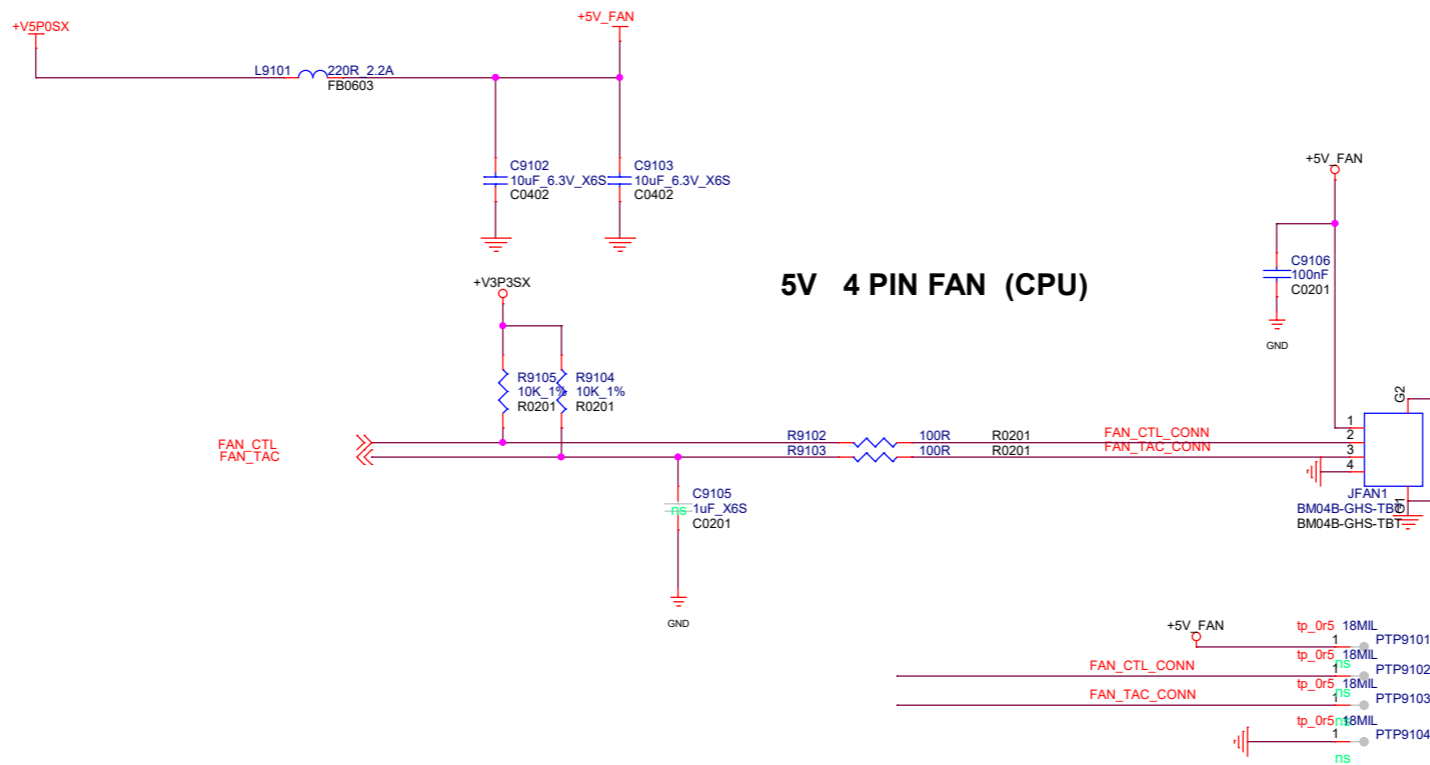

Namtso Technology Co., Ltd.			
Project:	A10-N305		
File:	Symbol(ME Screw Hole)		
Date:	Friday, February 02, 2024	Rev:	V12
Designed_by:	Victor Chen	Sheet:	37

POWER DELIVERY V3P0A&V5P0A

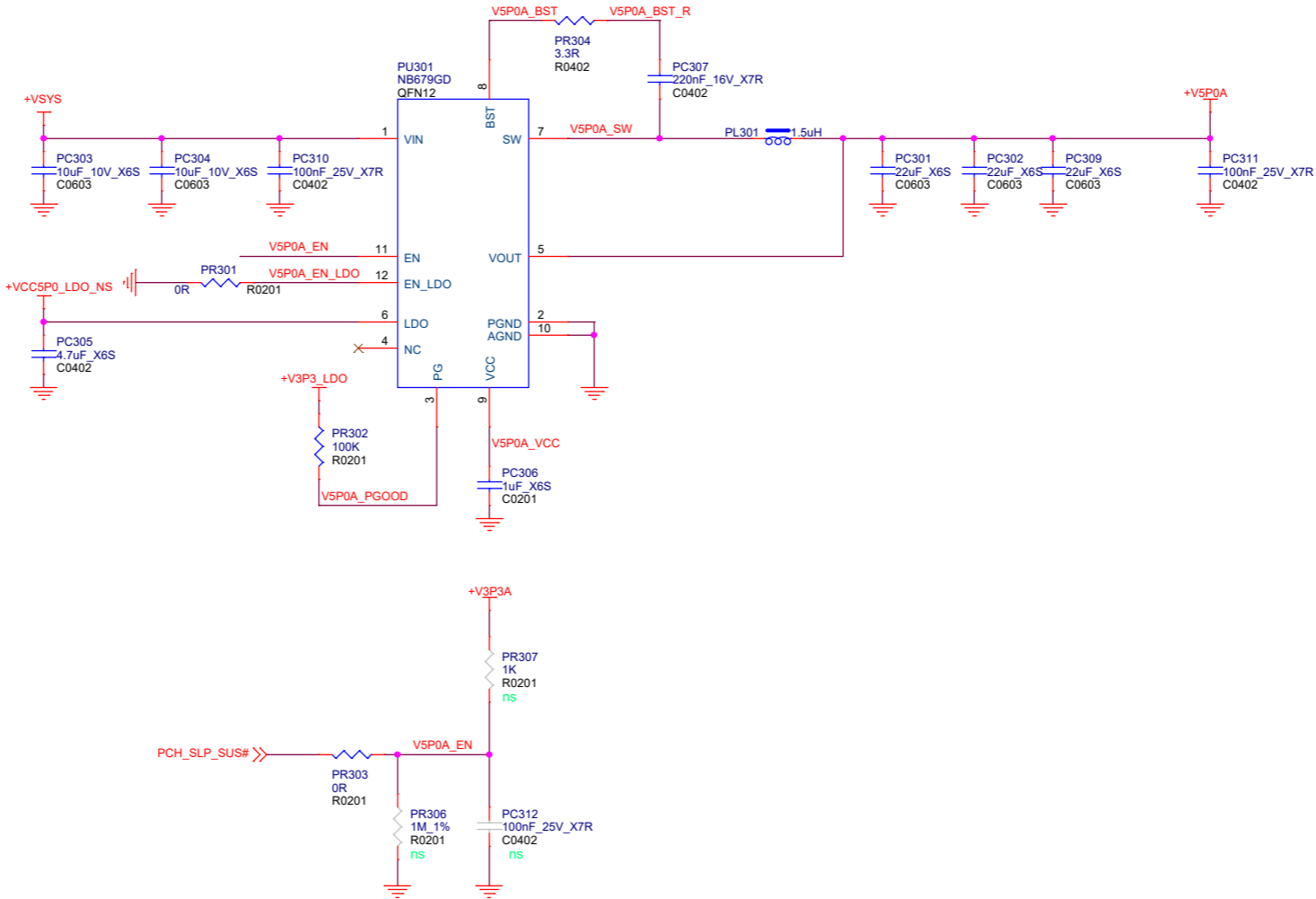
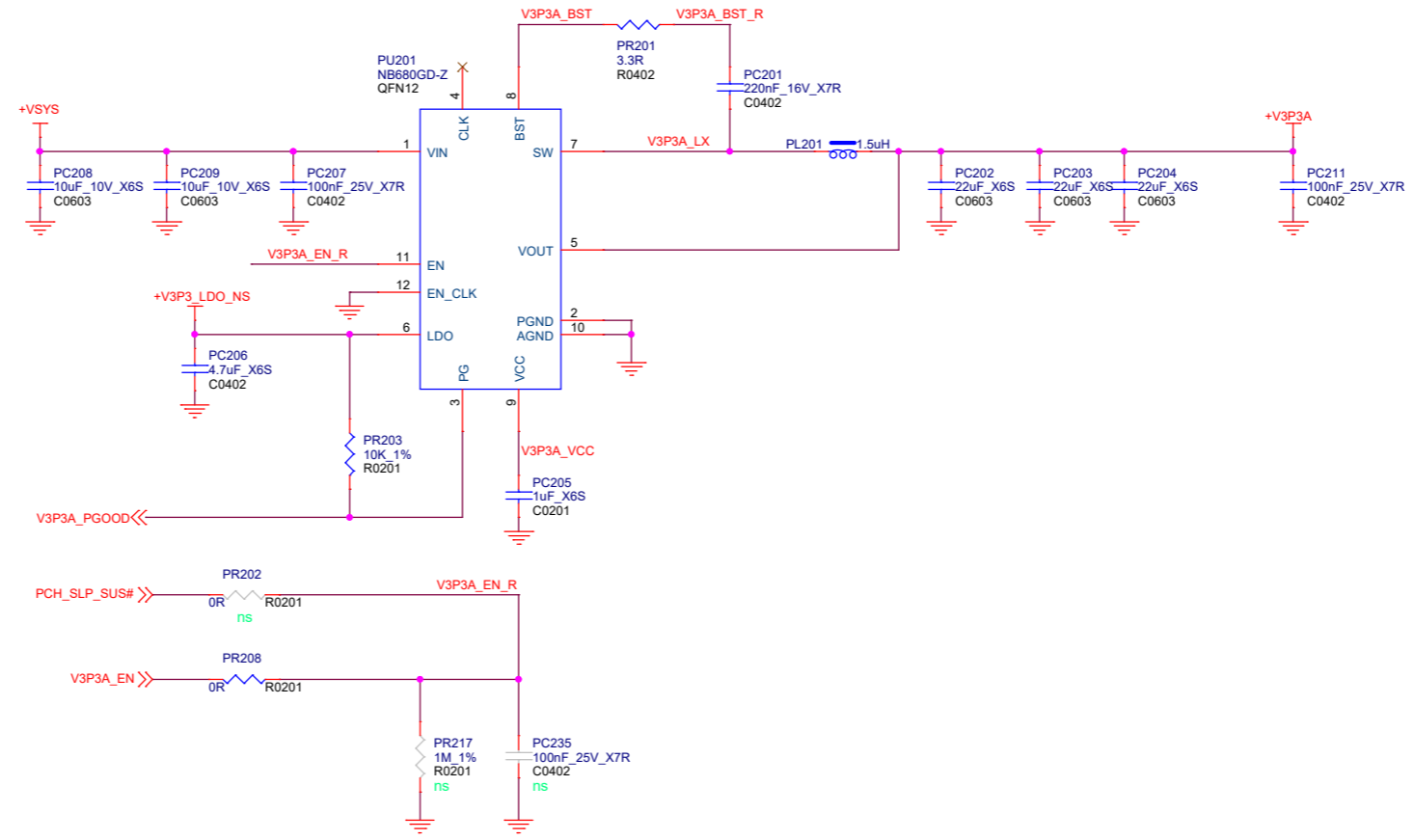

Namtso Technology Co., Ltd.			
Project:	A10-N305		
File:	101_POWER DELIVERY V3P0A&V5P0A		
Date:	Friday, February 02, 2024	Rev:	V12
Designed_by:	Evans.Wang	Sheet:	38

POWER DELIVERY DCIN&V1P8A

DCIN 12V~24V

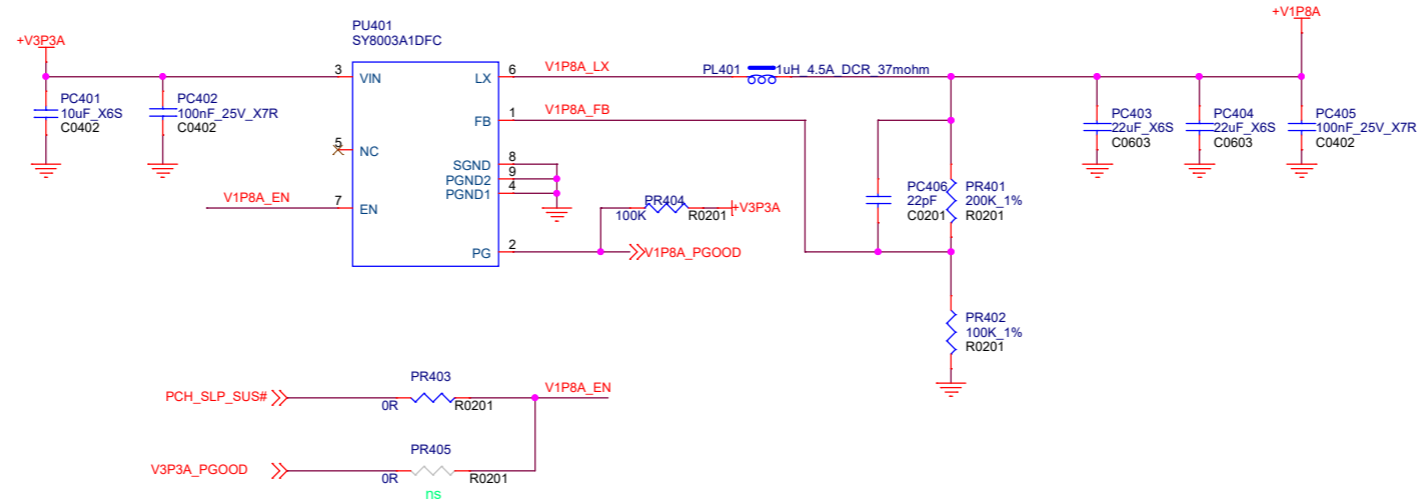

Namtso Technology Co., Ltd.			
Project:	A10-N305		
File:	102_POWER DELIVERY DCIN&V1P8A		
Date:	Friday, February 02, 2024	Rev:	V12
Designed_by:	Evans.Wang	Sheet:	39

POWER DELIVERY VDDQ

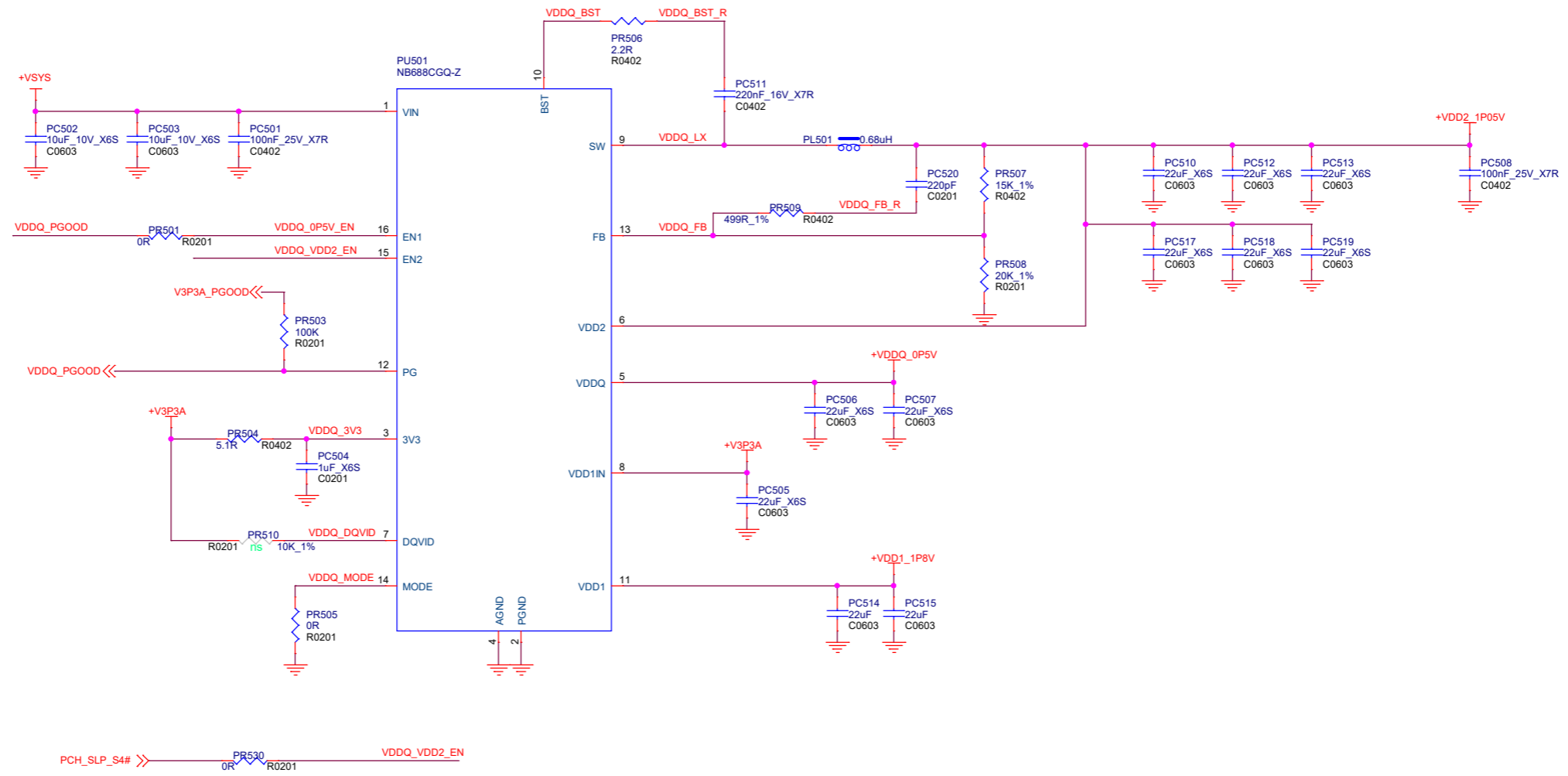

Namtso Technology Co., Ltd.			
Project:	A10-N305		
File:	103_POWER DELIVERY VDDQ		
Date:	Friday, February 02, 2024	Rev:	V12
Designed_by:	Evans.Wang	Sheet:	40

POWER DELIVERY IMVP9.2

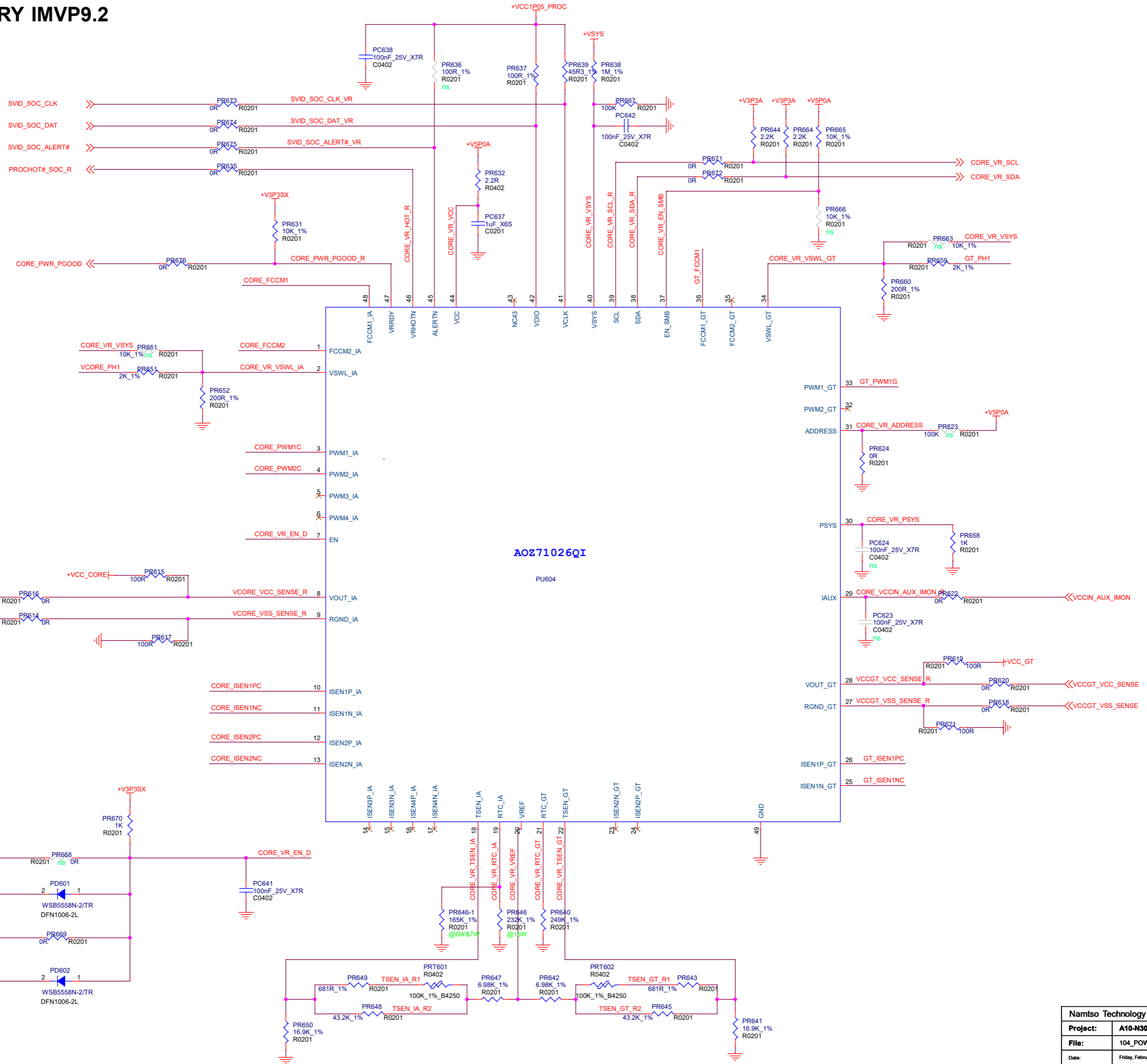

Namtso Technology Co., Ltd.			
Project:	A10-N305		
File:	104_POWER DELIVERY IMVP9.2		
Date:	Friday, February 02, 2024	Rev:	V12
Designed_by:	Evans.Wang	Sheet:	41

POWER DELIVERY VCC_CORE1

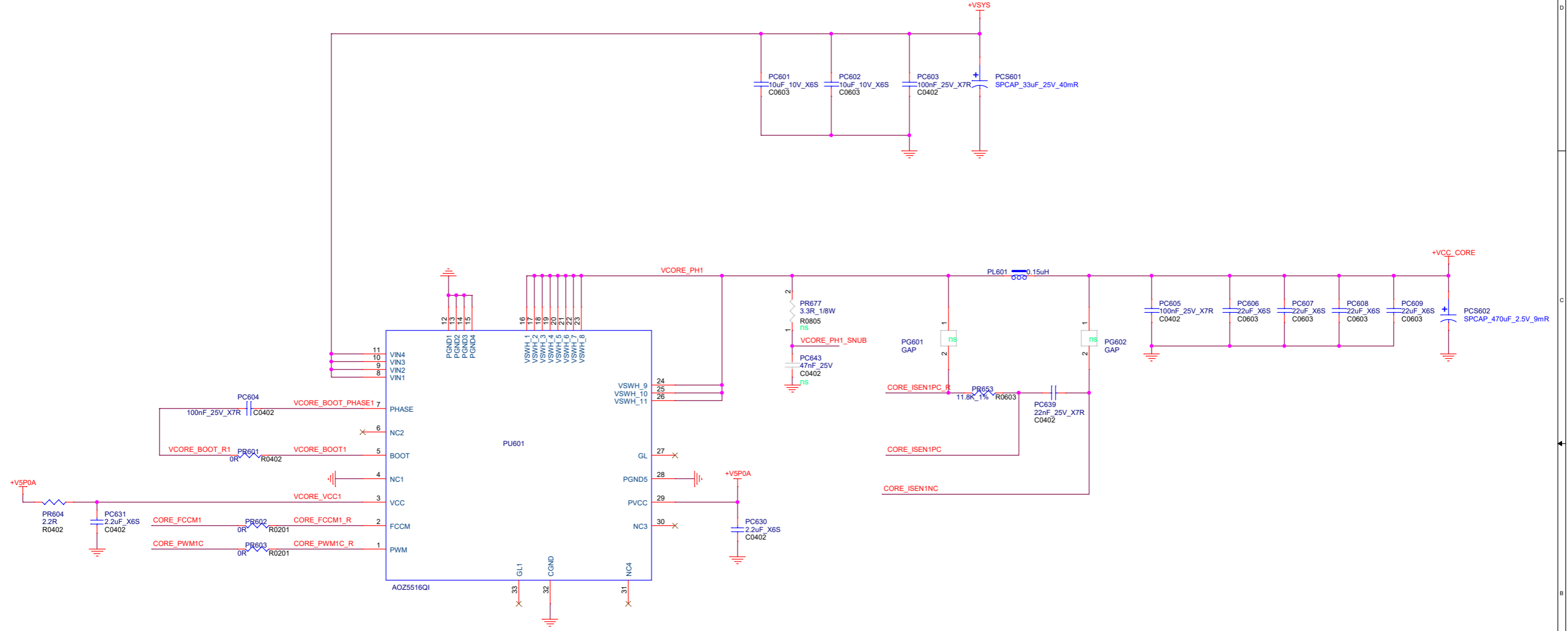

Namtso Technology Co., Ltd.			
Project:	A10-N305		
File:	105_POWER DELIVERY VCC_CORE1		
Date:	Friday, February 02, 2024	Rev:	V12
Designed_by:	Evans.Wang	Sheet:	42

POWER DELIVERY VCC_CORE2

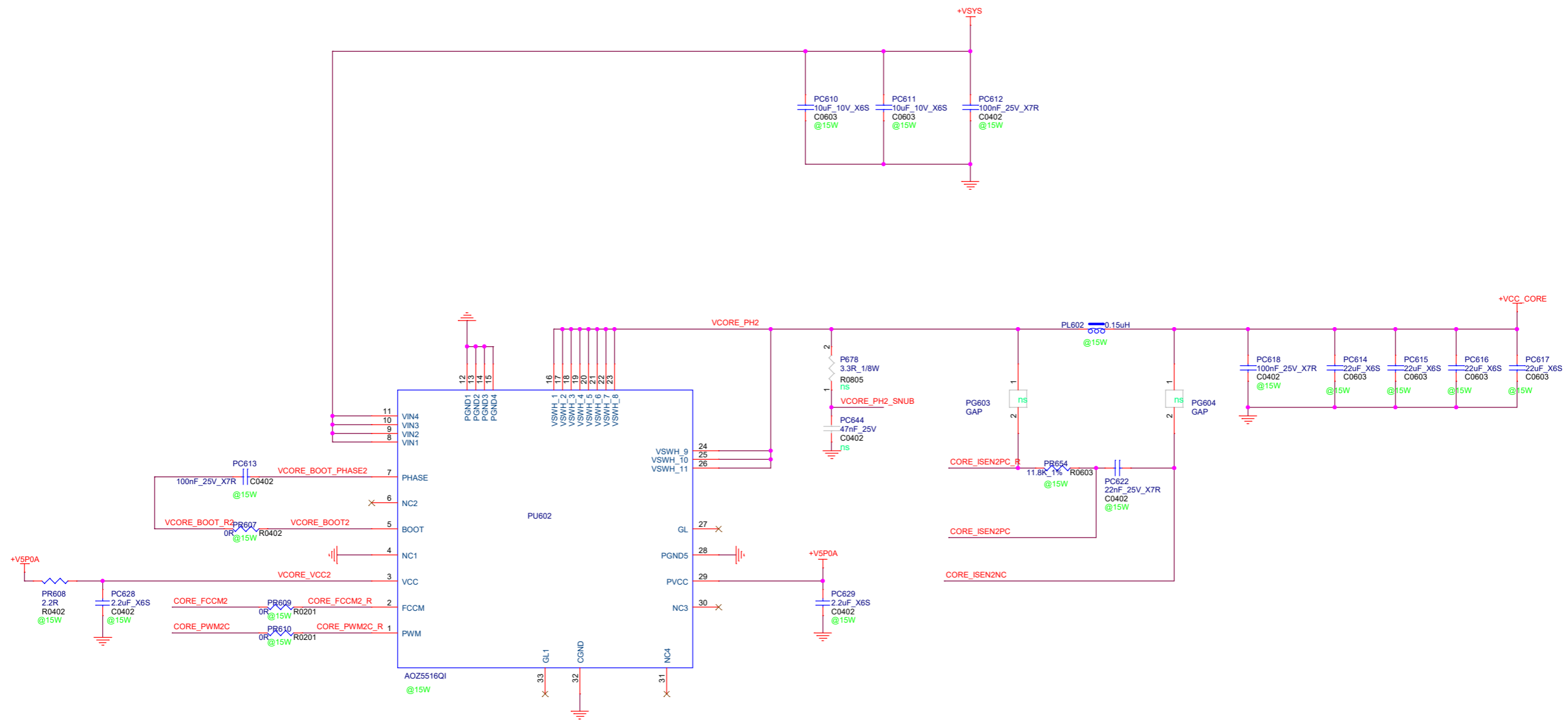

Namtso Technology Co., Ltd.			
Project:	A10-N305		
File:	106_POWER DELIVERY VCC_CORE2		
Date:	Friday, February 02, 2024	Rev:	V12
Designed_by:	Evans.Wang	Sheet:	43

POWER DELIVERY VCC_GT

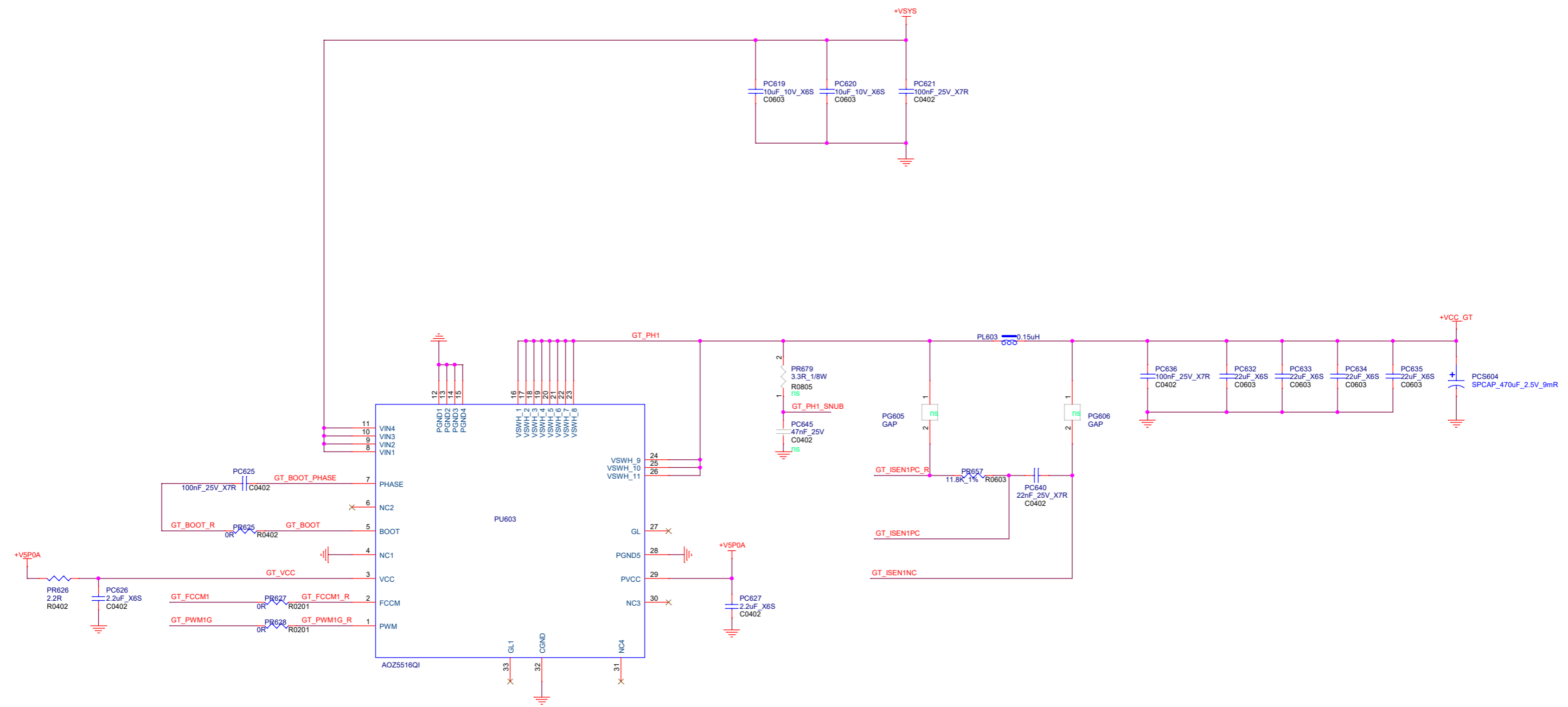

Namtso Technology Co., Ltd.			
Project:	A10-N305		
File:	107_POWER DELIVERY VCC_GT		
Date:	Friday, February 02, 2024	Rev:	V12
Designed_by:	Evans.Wang	Sheet:	44

POWER DELIVERY VCCIN_AUX

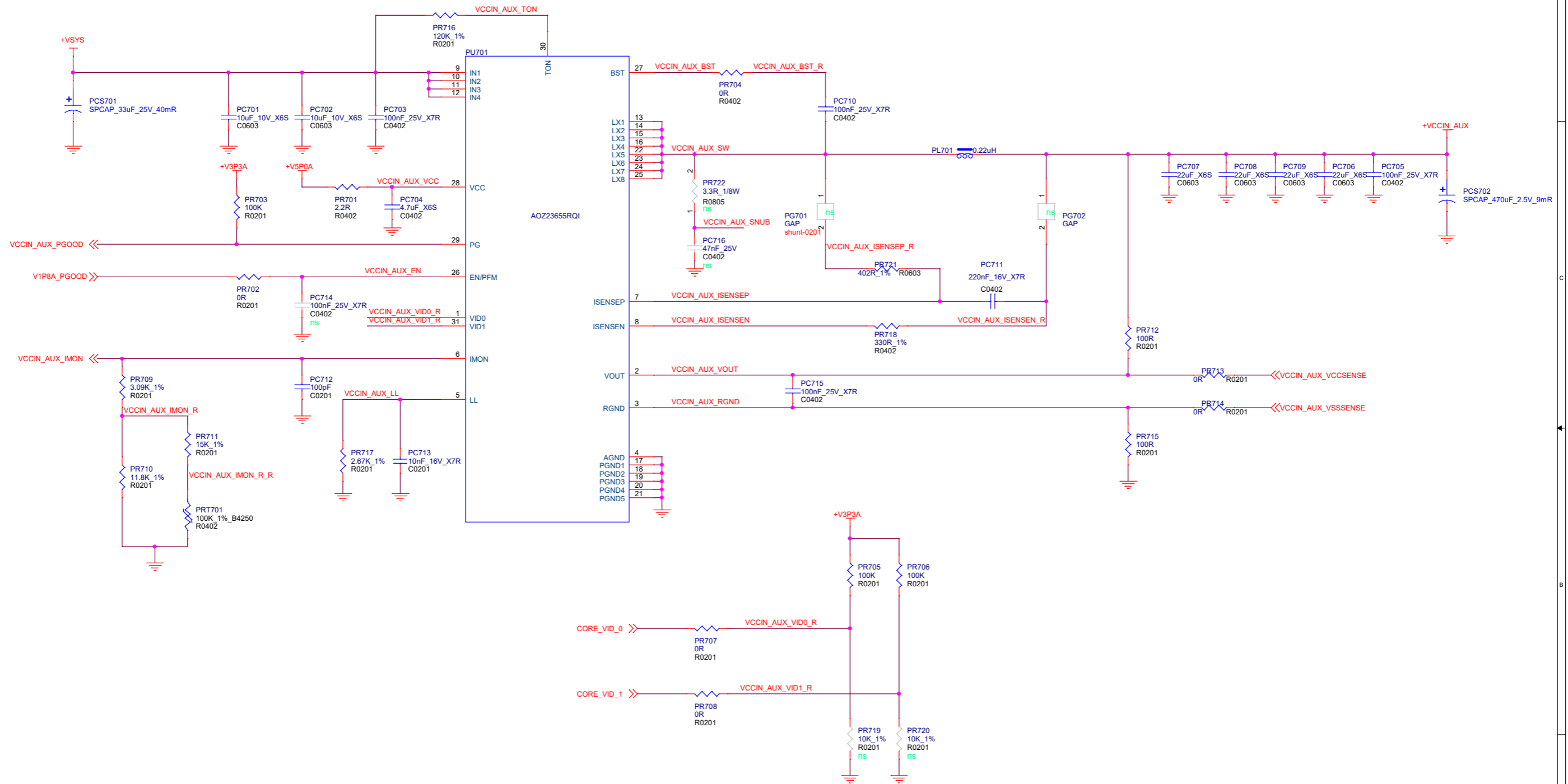

Namtso Technology Co., Ltd.			
Project:	A10-N305		
File:	108_POWER DELIVERY VCCIN_AUX		
Date:	Friday, February 02, 2024	Rev:	V12
Designed_by:	Evans.Wang	Sheet:	45

POWER DELIVERY VCC1P05_PROC

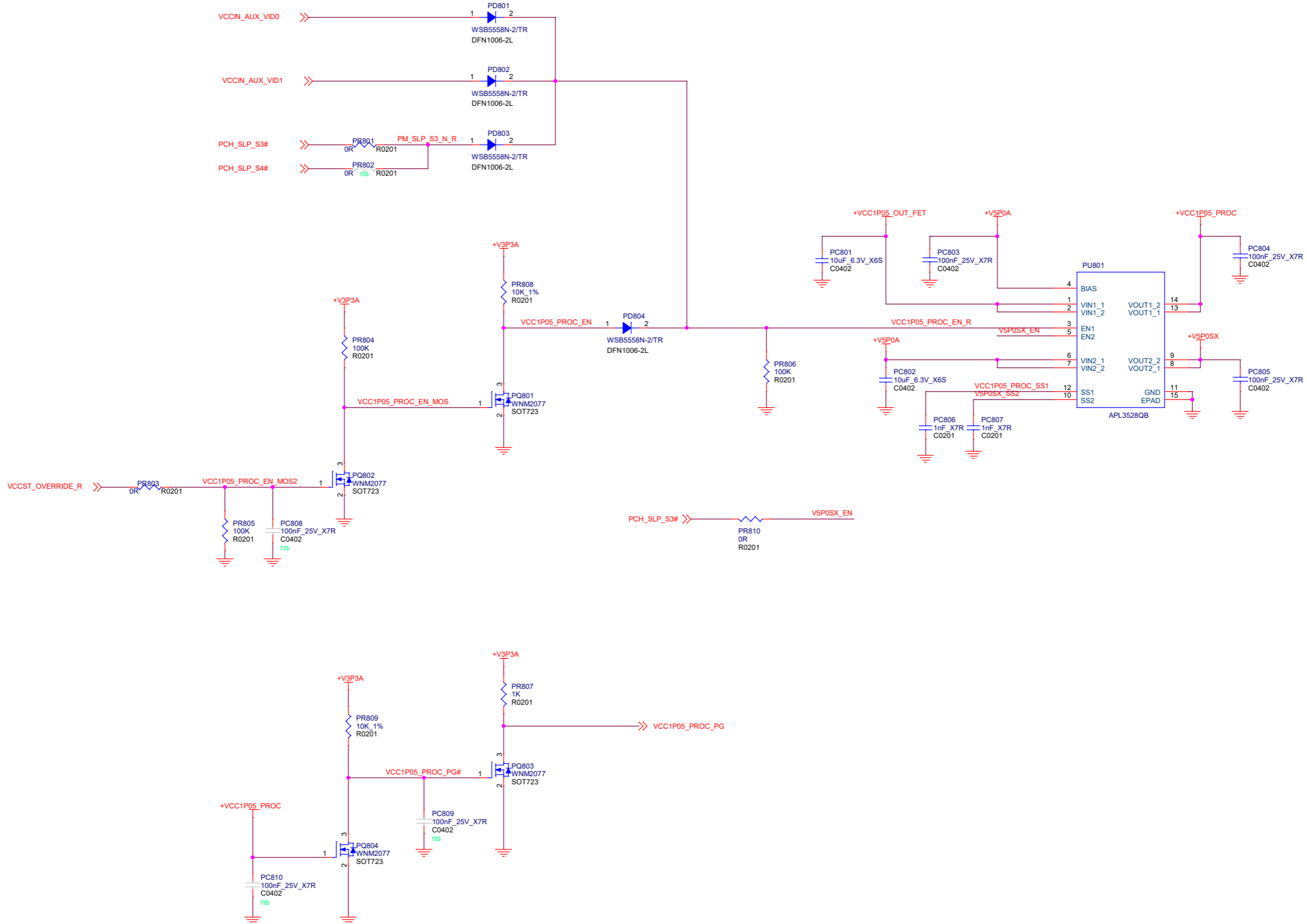

Namtso Technology Co., Ltd.			
Project:	A10-N305		
File:	109_POWER DELIVERY VCC1P05_PROC		
Date:	Friday, February 02, 2024	Rev:	V12
Designed_by:	Evans.Wang	Sheet:	46

POWER DELIVERY LS&LDO

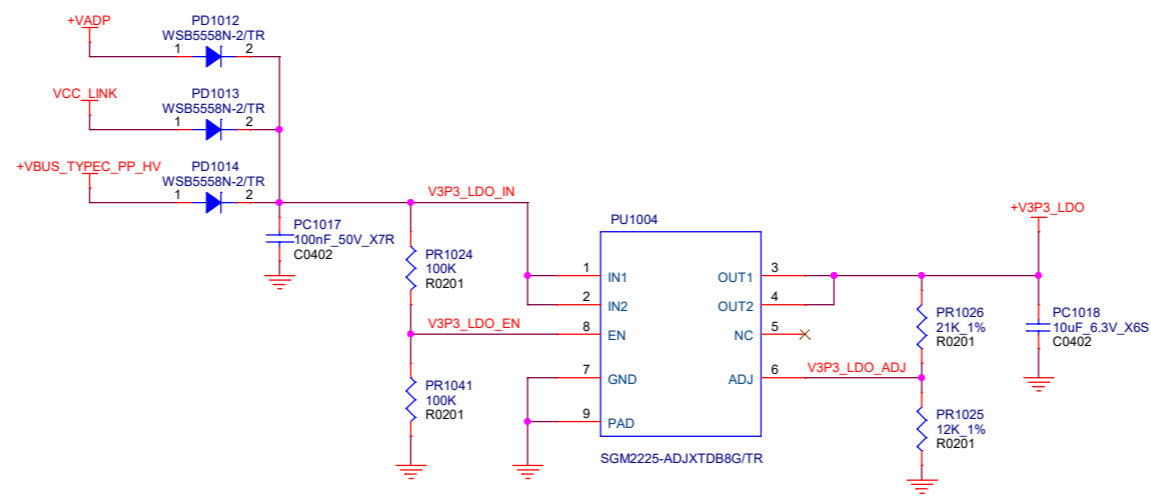
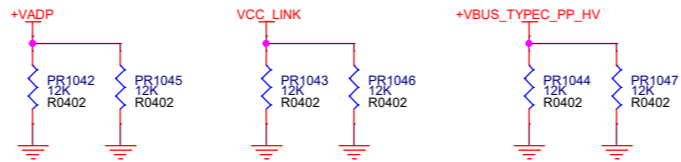
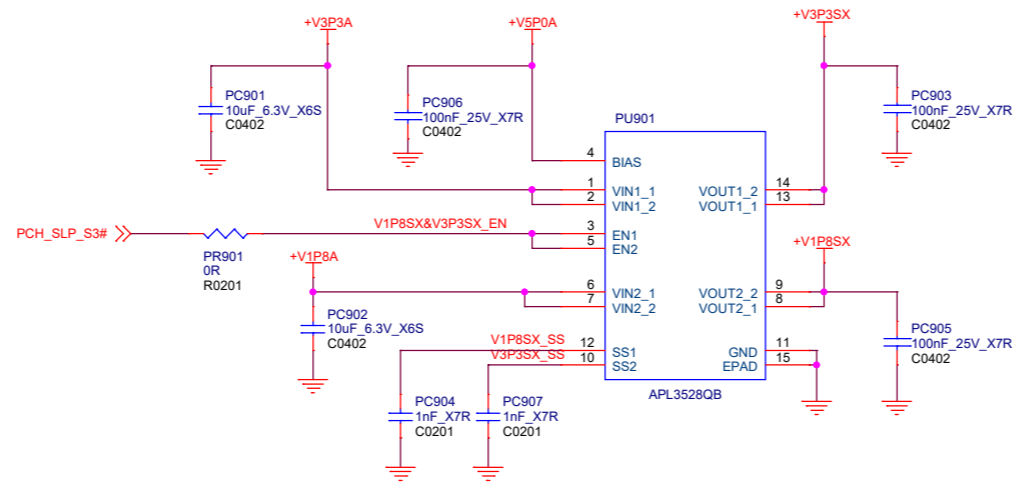

Namtso Technology Co., Ltd.			
Project:	A10-N305		
File:	110_POWER DELIVERY LS&LDO		
Date:	Friday, February 02, 2024	Rev:	V12
Designed_by:	Evans.Wang	Sheet:	47

POWER DELIVERY LINK_IN PATH

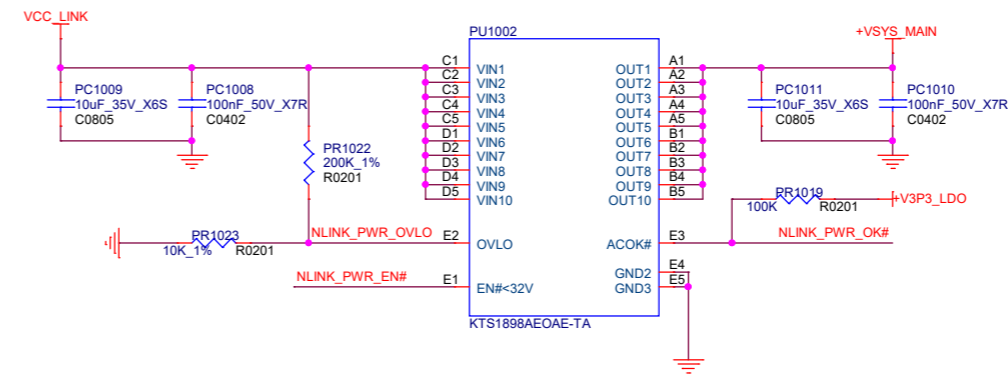
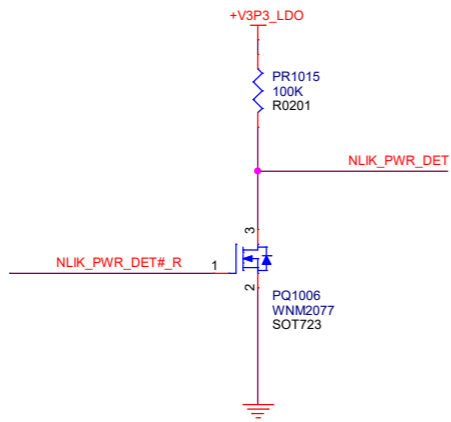
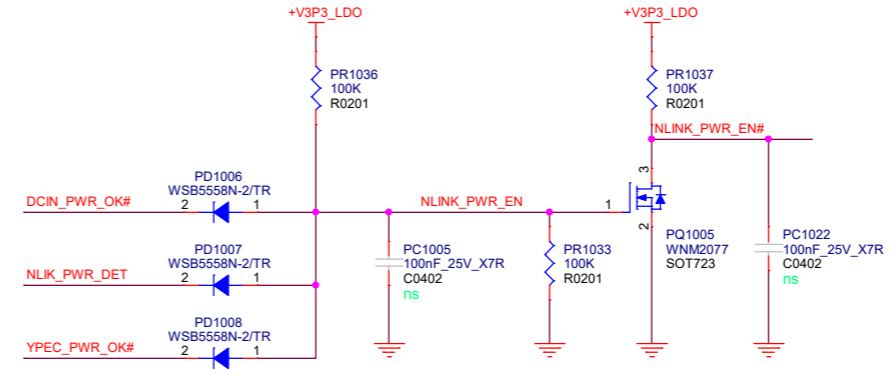
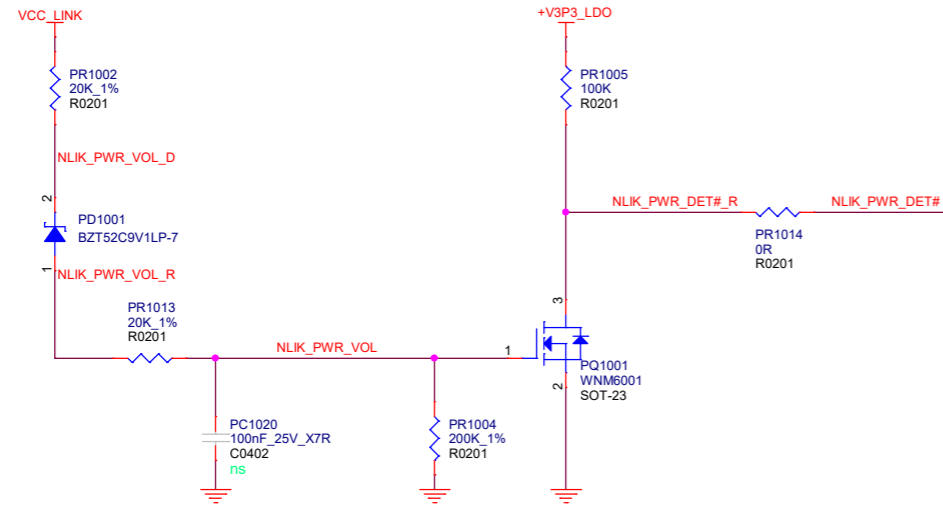

Namtso Technology Co., Ltd.			
Project:	A10-N305		
File:	111_POWER DELIVERY LINK_IN PATH		
Date:	Friday, February 02, 2024	Rev:	V12
Designed_by:	Evans.Wang	Sheet:	48

POWER DELIVERY DCIN_IN PATH

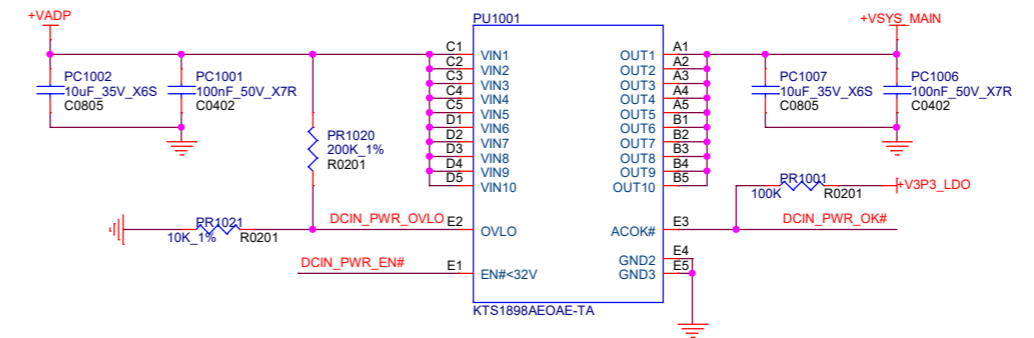
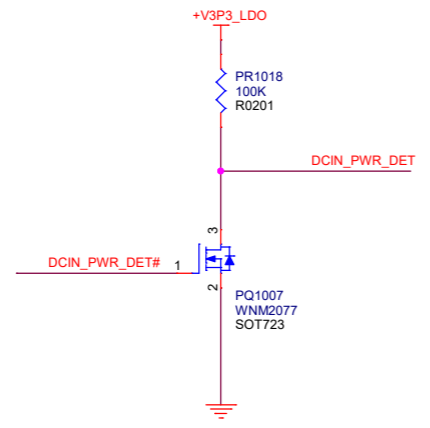
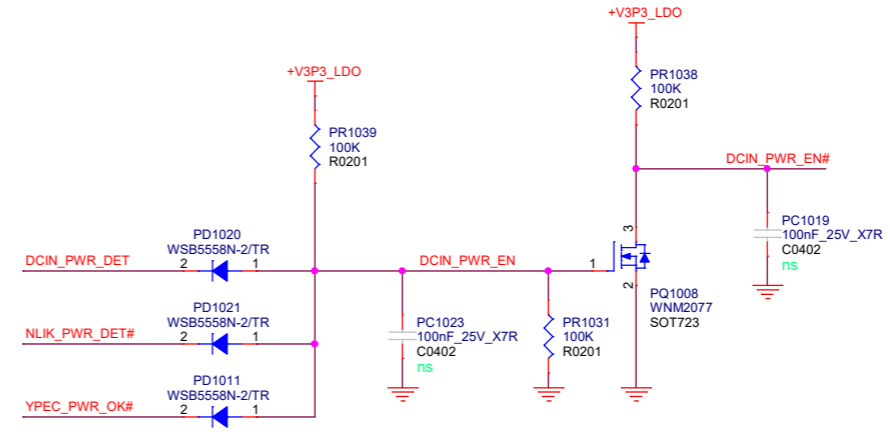
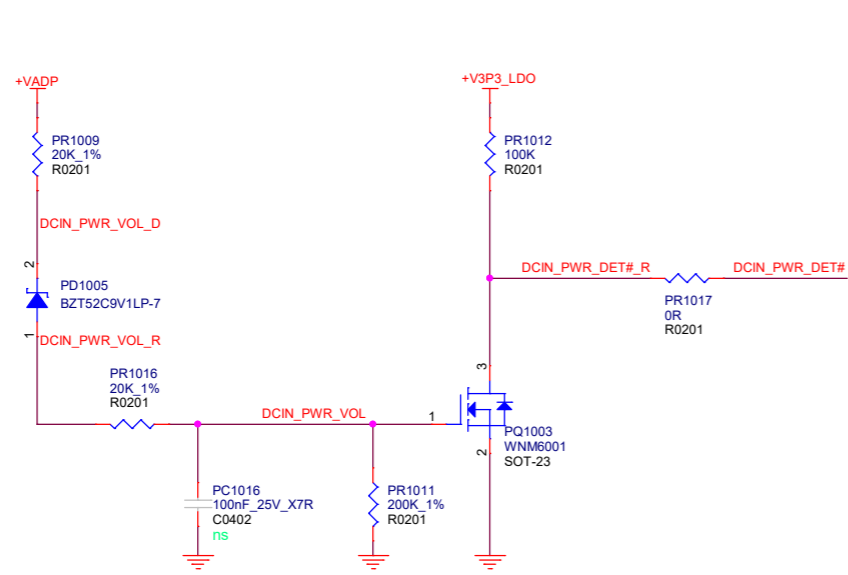

Namtso Technology Co., Ltd.			
Project:	A10-N305		
File:	112_POWER DELIVERY DCIN_IN PATH		
Date:	Friday, February 02, 2024	Rev:	V12
Designed_by:	Evans.Wang	Sheet:	49

POWER DELIVERY TYPC_IN PATH

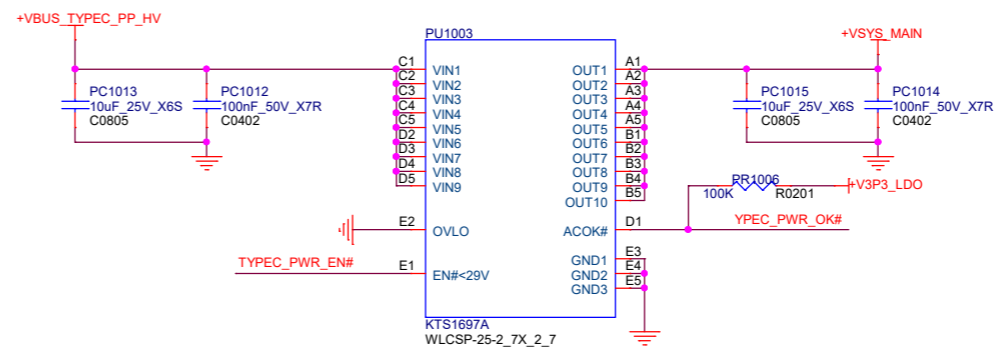
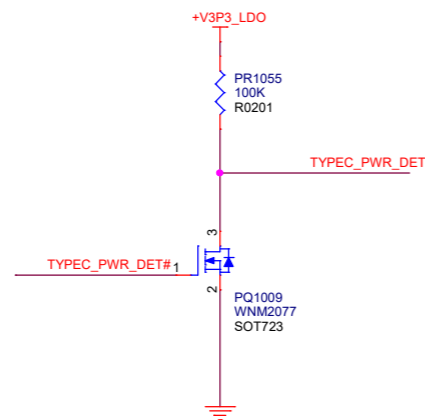
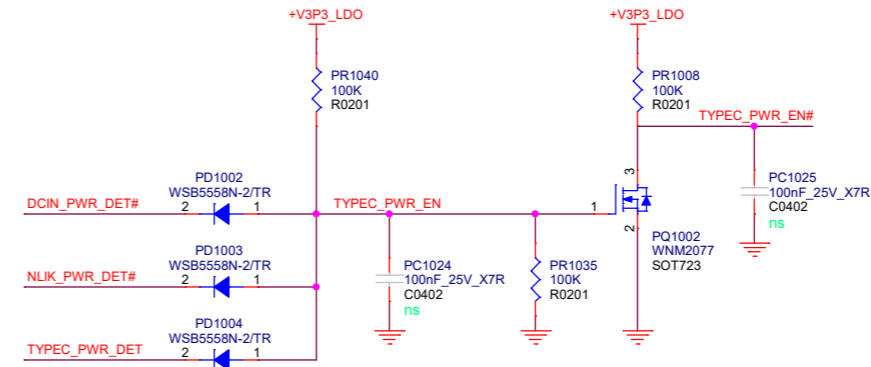
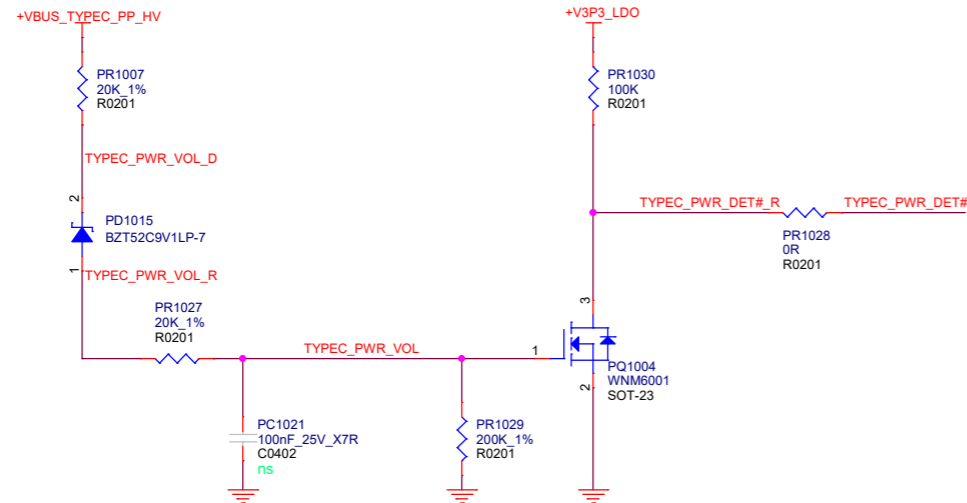

Namtso Technology Co., Ltd.			
Project:	A10-N305		
File:	113_POWER DELIVERY TYPC_IN PATH		
Date:	Friday, February 02, 2024	Rev:	V12
Designed_by:	Evans.Wang	Sheet:	50

POWER DELIVERY VSYS

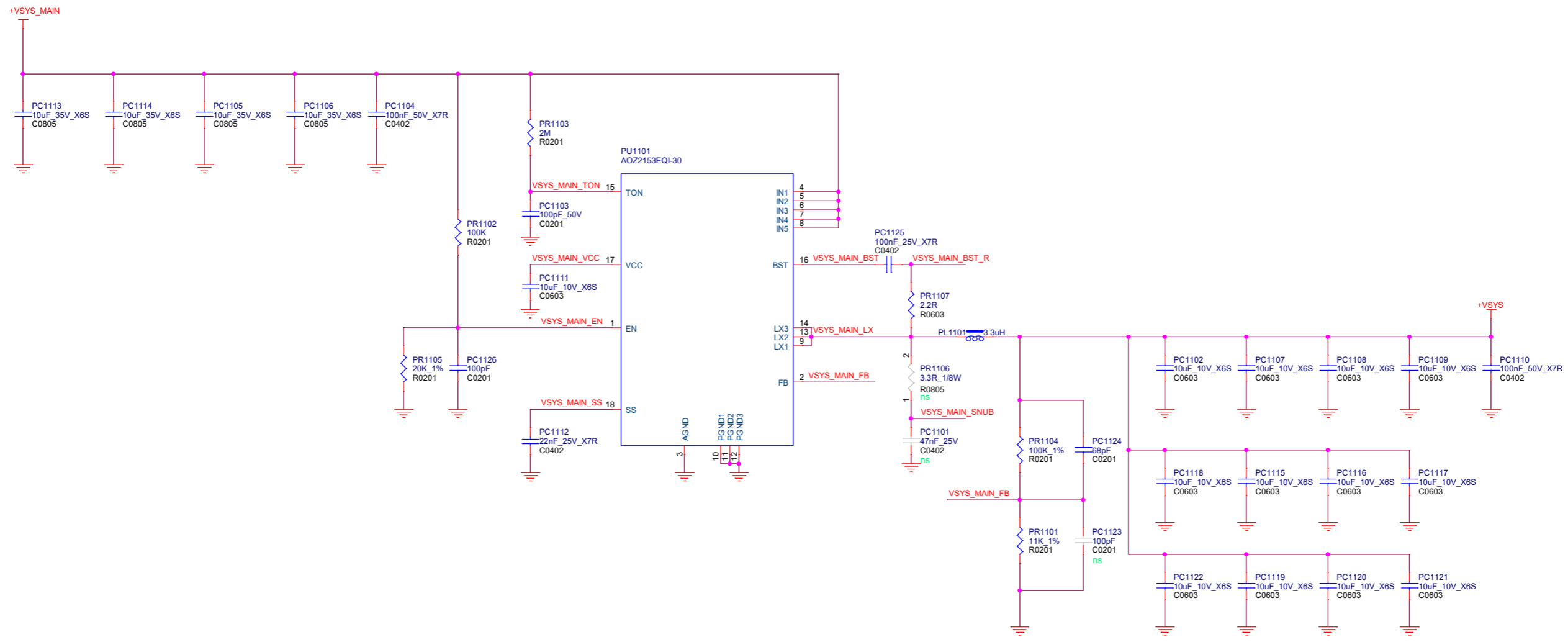

Namtso Technology Co., Ltd.			
Project:	A10-N305		
File:	114_POWER DELIVERY VSYS		
Date:	Friday, February 02, 2024	Rev:	V12
Designed_by:	Evans.Wang	Sheet:	51

POWER DELIVERY NLINK PATH

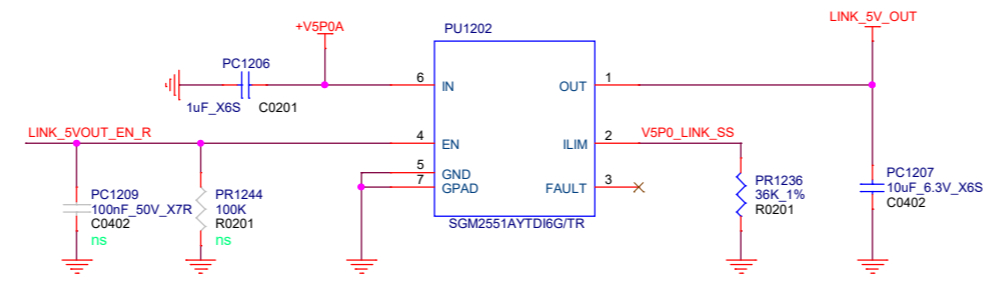
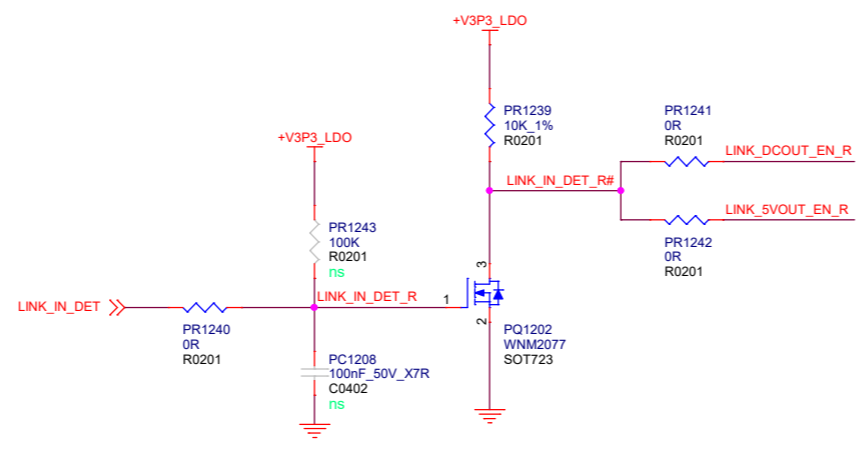
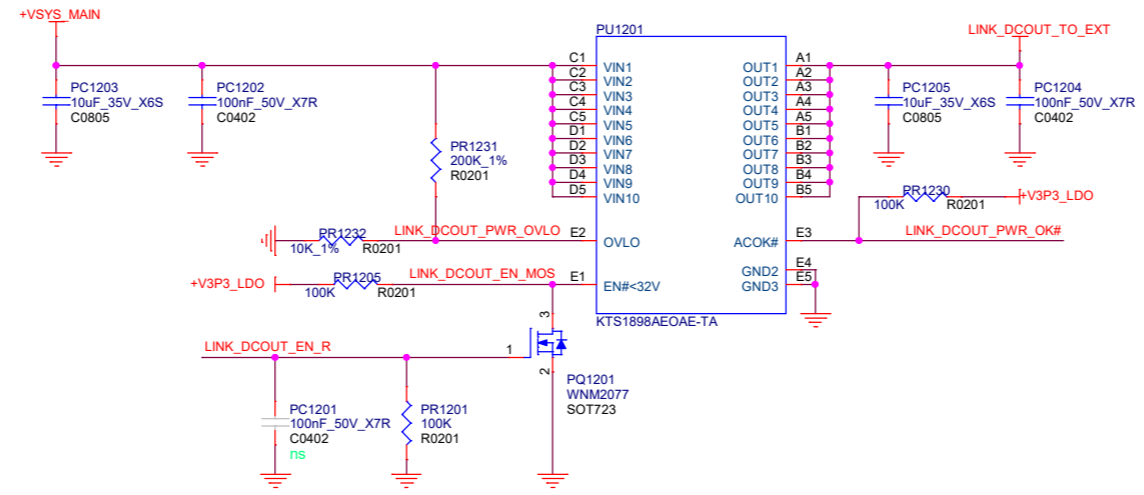

Namtso Technology Co., Ltd.			
Project:	A10-N305		
File:	115_POWER DELIVERY NLINK PATH		
Date:	Friday, February 02, 2024	Rev:	V12
Designed_by:	Evans.Wang	Sheet:	52

POWER DELIVERY CORE MLCC

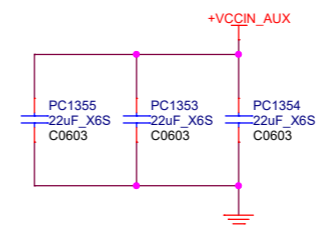
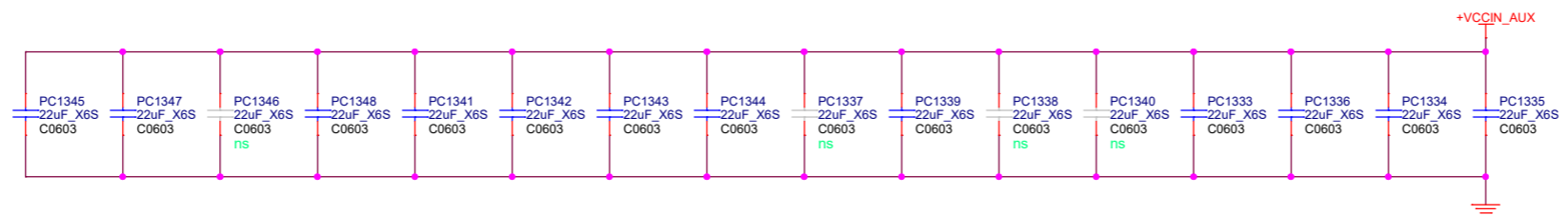
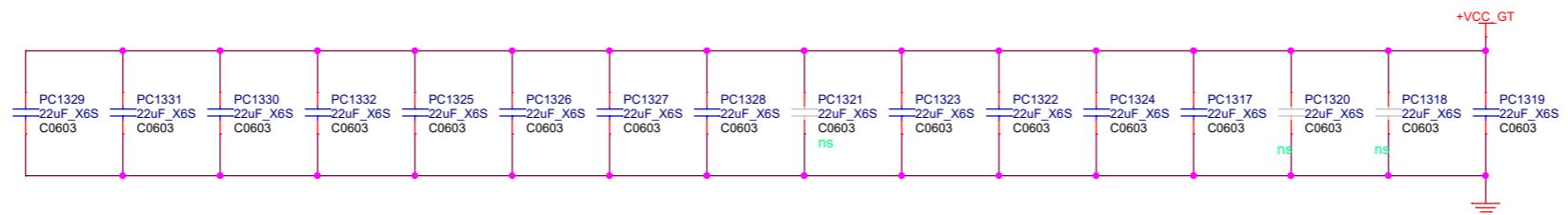
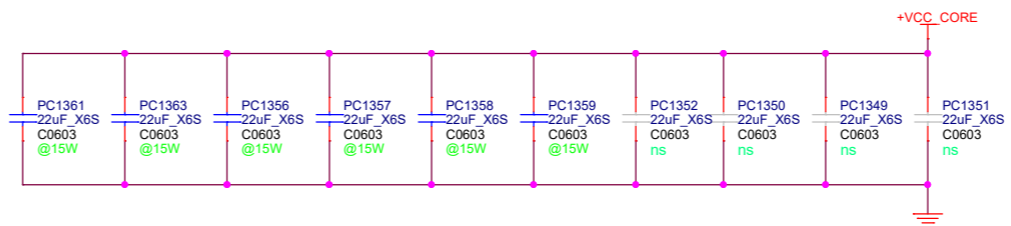
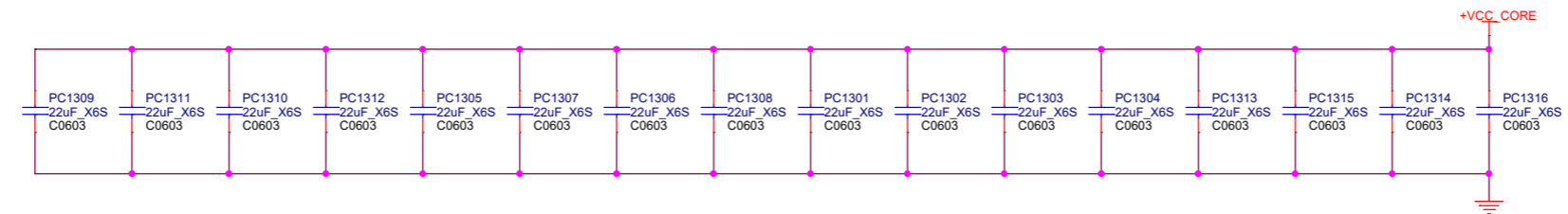

Namtso Technology Co., Ltd.			
Project:	A10-N305		
File:	116_POWER DELIVERY CORE MLCC		
Date:	Friday, February 02, 2024	Rev:	V12
Designed_by:	Evans.Wang	Sheet:	53

POWER DELIVERY V1P2A

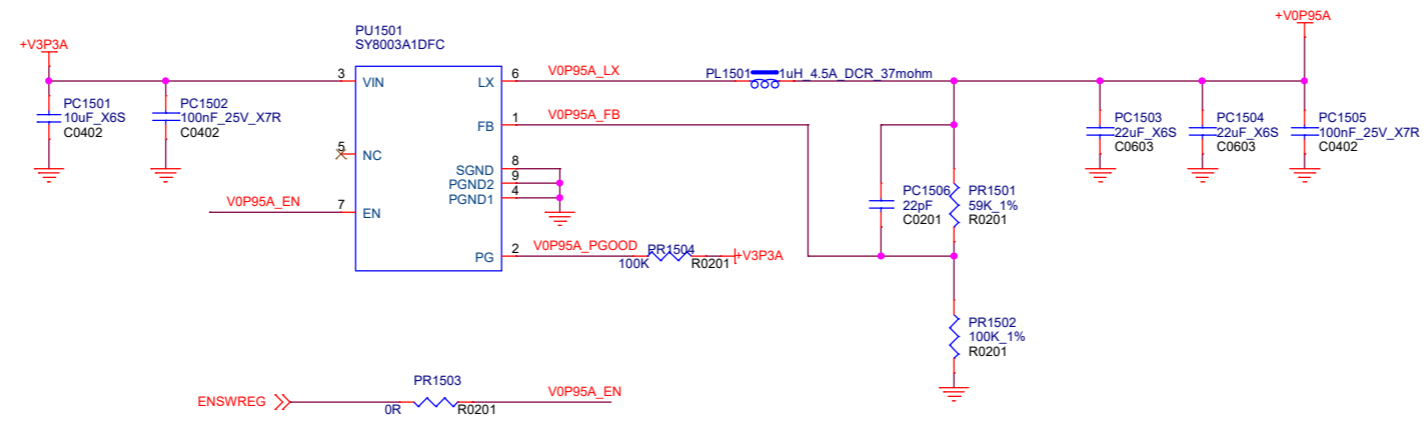
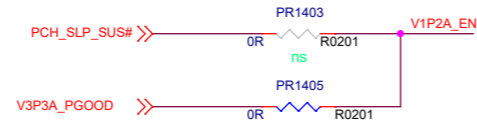
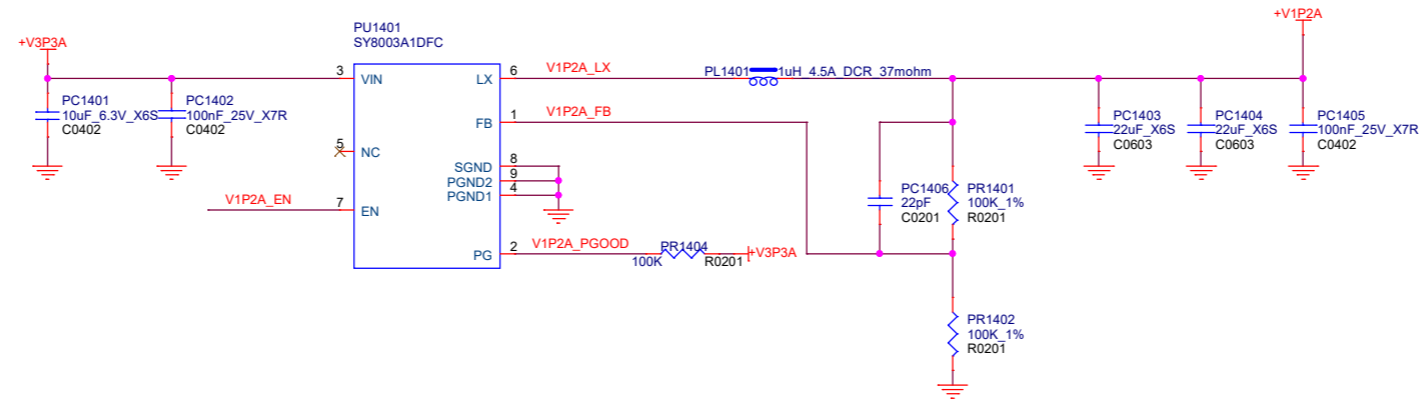

Namtso Technology Co., Ltd.			
Project:	A10-N305		
File:	117_POWER DELIVERY V1P2A		
Date:	Friday, February 02, 2024	Rev:	V12
Designed_by:	Evans.Wang	Sheet:	54